



# IEEE Guide for Protective Relay Applications to Distribution Lines

---

**IEEE Power Engineering Society**

Sponsored by the  
Power System Relaying Committee

C37.230<sup>TM</sup>

---

IEEE  
3 Park Avenue  
New York, NY 10016-5997, USA

8 February 2008

**IEEE Std C37.230<sup>TM</sup>-2007**



# IEEE Guide for Protective Relay Applications to Distribution Lines

Sponsor

**Power System Relaying Committee  
of the  
IEEE Power Engineering Society**

Approved 27 September 2007

**IEEE-SA Standards Board**

**Abstract:** A review of generally accepted applications and coordination of protection for radial power system distribution lines is presented. The advantages and disadvantages of schemes presently being used in protecting distribution lines are examined in this guide. Identification of problems with the methods used in distribution line protection and the solutions for those problems is included.

**Keywords:** coordination, protective reach, radial distribution line protection, recloser

---

The Institute of Electrical and Electronics Engineers, Inc.  
3 Park Avenue, New York, NY 10016-5997, USA

Copyright © 2008 by the Institute of Electrical and Electronics Engineers, Inc.  
All rights reserved. Published 8 February 2008. Printed in the United States of America.

IEEE is a registered trademark in the U.S. Patent & Trademark Office, owned by the Institute of Electrical and Electronics Engineers, Incorporated.

PDF: ISBN 978-0-7381-5711-5    STD95735  
Print: ISBN 978-0-7381-5712-2    STDPD95735

*No part of this publication may be reproduced in any form, in an electronic retrieval system or otherwise, without the prior written permission of the publisher.*

**IEEE Standards** documents are developed within the IEEE Societies and the Standards Coordinating Committees of the IEEE Standards Association (IEEE-SA) Standards Board. The IEEE develops its standards through a consensus development process, approved by the American National Standards Institute, which brings together volunteers representing varied viewpoints and interests to achieve the final product. Volunteers are not necessarily members of the Institute and serve without compensation. While the IEEE administers the process and establishes rules to promote fairness in the consensus development process, the IEEE does not independently evaluate, test, or verify the accuracy of any of the information contained in its standards.

Use of an IEEE Standard is wholly voluntary. The IEEE disclaims liability for any personal injury, property or other damage, of any nature whatsoever, whether special, indirect, consequential, or compensatory, directly or indirectly resulting from the publication, use of, or reliance upon this, or any other IEEE Standard document.

The IEEE does not warrant or represent the accuracy or content of the material contained herein, and expressly disclaims any express or implied warranty, including any implied warranty of merchantability or fitness for a specific purpose, or that the use of the material contained herein is free from patent infringement. IEEE Standards documents are supplied “**AS IS.**”

The existence of an IEEE Standard does not imply that there are no other ways to produce, test, measure, purchase, market, or provide other goods and services related to the scope of the IEEE Standard. Furthermore, the viewpoint expressed at the time a standard is approved and issued is subject to change brought about through developments in the state of the art and comments received from users of the standard. Every IEEE Standard is subjected to review at least every five years for revision or reaffirmation. When a document is more than five years old and has not been reaffirmed, it is reasonable to conclude that its contents, although still of some value, do not wholly reflect the present state of the art. Users are cautioned to check to determine that they have the latest edition of any IEEE Standard.

In publishing and making this document available, the IEEE is not suggesting or rendering professional or other services for, or on behalf of, any person or entity. Nor is the IEEE undertaking to perform any duty owed by any other person or entity to another. Any person utilizing this, and any other IEEE Standards document, should rely upon the advice of a competent professional in determining the exercise of reasonable care in any given circumstances.

Interpretations: Occasionally questions may arise regarding the meaning of portions of standards as they relate to specific applications. When the need for interpretations is brought to the attention of IEEE, the Institute will initiate action to prepare appropriate responses. Since IEEE Standards represent a consensus of concerned interests, it is important to ensure that any interpretation has also received the concurrence of a balance of interests. For this reason, IEEE and the members of its societies and Standards Coordinating Committees are not able to provide an instant response to interpretation requests except in those cases where the matter has previously received formal consideration. At lectures, symposia, seminars, or educational courses, an individual presenting information on IEEE standards shall make it clear that his or her views should be considered the personal views of that individual rather than the formal position, explanation, or interpretation of the IEEE.

Comments for revision of IEEE Standards are welcome from any interested party, regardless of membership affiliation with IEEE. Suggestions for changes in documents should be in the form of a proposed change of text, together with appropriate supporting comments. Comments on standards and requests for interpretations should be addressed to:

Secretary, IEEE-SA Standards Board  
445 Hoes Lane  
Piscataway, NJ 08854  
USA

Authorization to photocopy portions of any individual standard for internal or personal use is granted by the Institute of Electrical and Electronics Engineers, Inc., provided that the appropriate fee is paid to Copyright Clearance Center. To arrange for payment of licensing fee, please contact Copyright Clearance Center, Customer Service, 222 Rosewood Drive, Danvers, MA 01923 USA; +1 978 750 8400. Permission to photocopy portions of any individual standard for educational classroom use can also be obtained through the Copyright Clearance Center.

## Introduction

This introduction is not part of IEEE Std C37.230-2007, IEEE Guide for Protective Relay Applications to Distribution Lines.

The art and science of the protective relaying of distribution lines has evolved over many years. This newly developed guide is an effort to compile information on the application considerations of protective relays to power distribution lines. This guide presents a review of generally accepted distribution line protection schemes. Its purpose is to describe various schemes used for different conditions and situations and to assist relay engineers in selecting the most appropriate scheme for a particular installation. It is intended for engineers who have a basic knowledge of power system protection. This is an application guide and does not cover all of the protective requirements of all distribution line configurations in every situation. Additional reading material is suggested so the reader can evaluate the protection for the individual application.

## Notice to users

### Errata

Errata, if any, for this and all other standards can be accessed at the following URL: <http://standards.ieee.org/reading/ieee/updates/errata/index.html>. Users are encouraged to check this URL for errata periodically.

### Interpretations

Current interpretations can be accessed at the following URL: <http://standards.ieee.org/reading/ieee/interp/index.html>.

### Patents

Attention is called to the possibility that implementation of this guide may require use of subject matter covered by patent rights. By publication of this guide, no position is taken with respect to the existence or validity of any patent rights in connection therewith. The IEEE is not responsible for identifying Essential Patent Claims for which a license may be required, for conducting inquiries into the legal validity or scope of Patent Claims, or determining whether any licensing terms or conditions are reasonable or non-discriminatory. Further information may be obtained from the IEEE Standards Association.

## Participants

At the time this guide was submitted to the IEEE-SA Standards Board for approval, the Guide for Protective Applications to Distribution Lines Working Group had the following membership:

**William P. Waudby**, *Chair*  
**Randall P. Crellin**, *Vice Chair*

John C. Appleyard  
Ron Beazer  
Ken Behrendt  
Martin Best  
Kenneth A. Birt  
Gustavo Brunello  
Jim Burke  
Pat T. Carroll  
Albert N. Darlington  
Ratan Das  
Ahmed F. Elneweihi  
Fredric A. Friend  
Rafael Garcia

Irwin O. Hasenwinkle  
Roger A. Hedding  
Randy Horton  
Richard K. Hunt  
Shoukat Khan  
Ljubomir Kojovic  
Ed Krizauskas  
Raluca Lascu  
Larry P. Lawhead  
Walter McCannon  
Michael J. McDonald  
Dean H. Miller  
Anthony P. Napikoski

Robert D. Pettigrew  
Sam N. Sambasivan  
Mark S. Schroeder  
Tony Seegers  
Tarlochan Sidhu  
Charlie R. Sufana  
Jon A. Sykes  
Betty Tobin  
Joe Uchiyama  
Ron M. Westfall  
Inma Zamora  
Karl V. Zimmerman  
Stan E. Zocholl

The following members of the individual balloting committee voted on this guide. Balloters may have voted for approval, disapproval, or abstention.

William J. Ackerman  
Steven C. Alexanderson  
Ali Al Awazi  
Thomas M. Barnes  
David L. Bassett  
Thomas S. Basso  
Ron Beazer  
Ken Behrendt  
Robert W. Beresh  
W. J. Bergman  
Martin Best  
Steven Bezner  
Wallace B. Binder  
Kenneth A. Birt  
William G. Bloethe  
Oscar E. Bolado  
Stuart H. Bouchey  
Steven R. Brockschink  
Chris Brooks  
Gustavo Brunello  
William A. Byrd  
Thomas P. Callsen  
Thomas Carpenter  
James S. Case  
John W. Chadwick  
Stephen P. Conrad  
Tommy P. Cooper  
James Cornelison  
Randy Crellin  
Stephen Dare  
Ratan Das  
F. A. Denbrock  
Kevin E. Donahoe  
Michael J. Dood  
Randall L. Dotson  
Paul R. Drum  
Donald G. Dunn  
Gary Engmann  
Marcel Fortin

Fredric A. Friend  
Jeffrey G. Gilbert  
Manuel Gonzalez  
Ron K. Greenthaler  
Stephen E. Grier  
Randall C. Groves  
Kenneth Hanus  
Roger A. Hedding  
Michael Henry  
Charles F. Henville  
Scott J. Hietpas  
Jerry W. Hohn  
Randy Horton  
James D. Huddleston  
David W. Jackson  
Innocent Kamwa  
Peter J. Kemp  
Hermann Koch  
Joseph L. Koepfinger  
David W. Krause  
Ed Krizauskas  
Jim Kulchisky  
Chung-Yiu Lam  
Raluca Lascu  
Federico Lopez  
William G. Lowe  
G. Luri  
Omar S. Mazzoni  
Walter McCannon  
Michael J. McDonald  
Mark F. McGranaghan  
Gary L. Michel  
Dean H. Miller  
Charles A. Morse  
Kimberly Y. Mosley  
Jerry R. Murphy  
George R. Nail  
Anthony P. Napikoski

Dennis K. Neitzel  
Arthur S. Neubauer  
Michael S. Newman  
Joe W. Nims  
James M. O'Brien  
Lorraine K. Padden  
Joshua S. Park  
Donald M. Parker  
Robert D. Pettigrew  
Iulian E. Profir  
Michael A. Roberts  
Charles W. Rogers  
Thomas J. Rozek  
M. S. Sachdev  
Steven Sano  
Thomas Schossig  
Tony Seegers  
Bogdan Seliger  
Hyeong J. Sim  
Mark S. Simon  
Douglas W. Smith  
James E. Smith  
Jerry W. Smith  
Joshua B. Smith  
Charlie R. Sufana  
Richard P. Taylor  
S. H. Telander  
S. Thamilarsan  
Demetrios A. Tziouvaras  
Joe D. Watson  
William P. Waudby  
Lee E. Welch  
Kenneth White  
James W. Wilson  
Philip B. Winston  
James A. Ziebarth  
Karl V. Zimmerman  
Donald W. Zipse  
Ahmed F. Zobaa

When the IEEE-SA Standards Board approved this guide on 27 September 2007, it had the following membership:

**Steve M. Mills**, *Chair*  
**Robert M. Grow**, *Vice Chair*  
**Don Wright**, *Past Chair*  
**Judith Gorman**, *Secretary*

Richard DeBlasio  
Alex Gelman  
William R. Goldbach  
Arnold M. Greenspan  
Joanna N. Guenin  
Kenneth S. Hanus  
William B. Hopf  
Richard H. Hulett

Hermann Koch  
Joseph L. Koepfinger\*  
John Kulick  
David J. Law  
Glenn Parsons  
Ronald C. Petersen  
Tom A. Prevost

Narayanan Ramachandran  
Greg Ratta  
Robby Robson  
Anne-Marie Sahazizian  
Virginia C. Sulzberger  
Malcolm V. Thaden  
Richard L. Townsend  
Howard L. Wolfman

\*Member Emeritus

Also included are the following nonvoting IEEE-SA Standards Board liaisons:

Satish K. Aggarwal, *NRC Representative*  
Michael H. Kelley, *NIST Representative*

Don Messina  
*IEEE Standards Program Manager, Document Development*

Matthew J. Ceglia  
*IEEE Standards Program Manager, Technical Program Development*

## Contents

1. Overview .....	1
1.1 Scope .....	1
1.2 Purpose .....	1
2. Normative references.....	1
3. Definitions .....	2
4. Fundamentals.....	2
4.1 Fault characteristics .....	2
4.2 Load characteristics .....	4
4.3 Harmonics and transients.....	4
4.4 Interrupting ratings .....	7
5. System configuration and components .....	7
5.1 System .....	7
5.2 Lines .....	28
5.3 Transformer—Distribution substation .....	29
5.4 Protective devices .....	30
5.5 Switching.....	32
5.6 Instrument transformers (sensing) .....	32
6. Protective schemes .....	39
6.1 Overcurrent scheme .....	39
6.2 Fuse saving/blowing schemes.....	41
6.3 Voltage scheme.....	43
6.4 Impedance and communications assisted schemes .....	46
7. Criteria and examples .....	46
7.1 Reach/sensitivity.....	47
7.2 Coordination .....	52
7.3 Clearing time .....	58
7.4 Reclosing (79 function) .....	59
7.5 Cold load pickup.....	60
7.6 Adaptive relaying cold load.....	60
7.7 Fuse saving .....	61
8. Special applications .....	62
8.1 Parallel lines .....	62
8.2 Automation .....	62
8.3 Load shedding.....	64
8.4 Adaptive relaying schemes .....	65

8.5 Multiple faults.....	65
8.6 Sympathetic tripping.....	66
8.7 Distributed resources .....	66
8.8 Communications.....	69
8.9 Multiple source configurations .....	72
8.10 Directional overcurrent relay .....	73
8.11 Motors (effects of unbalance).....	75
8.12 Breaker failure.....	77
8.13 Single-phase tripping .....	78
8.14 Resonant grounding in distribution systems.....	79
8.15 Selective ground fault protection of an ungrounded system.....	82
 Annex A (informative) Bibliography .....	 85
 Annex B (informative) Glossary .....	 89



# IEEE Guide for Protective Relay Applications to Distribution Lines

## 1. Overview

This guide is divided into eight clauses. Clause 1 provides the scope and purpose of this guide. Clause 2 lists referenced documents that are indispensable when applying this guide. Clause 3 provides definitions that are not found in other standards. Clause 4 gives an explanation of distribution fundamentals. Clause 5 discusses system configuration and components. Clause 6 explains the characteristics of protective schemes. Criteria and examples are discussed in Clause 7, including margins and normal considerations. Clause 8 has several special applications and considerations for distribution line protection.

This guide also contains two annexes. Annex A provides the bibliography, and Annex B contains a glossary of terms defined in other IEEE standards.

### 1.1 Scope

The scope of this guide is to discuss the application and coordination of protection for radial power-system distribution lines. It includes the descriptions of the fundamentals, line configurations, and schemes. In addition to these, the scope includes identification of problems with the methods used in distribution line protection and the solutions for those problems.

### 1.2 Purpose

This guide educates and provides information on distribution protection schemes to utility engineers, consultants, educators, and manufacturers. The guide examines the advantages and disadvantages of schemes presently used in protecting distribution lines. This provides the user with the rationale for determining the best approach for protecting an electric power distribution system.

## 2. Normative references

The following referenced documents are indispensable for the application of this guide (i.e., they must be understood and used, so each referenced document is cited in text and its relationship to this document is explained). For dated references, only the edition cited applies. For undated references, the latest edition of the referenced document (including any amendments or corrigenda) applies.

IEEE Std C57.13™, IEEE Standard Requirements for Instrument Transformers.<sup>1, 2</sup>

IEEE Std C62.92.4™, IEEE Guide for the Application of Neutral Grounding in Electrical Utility Systems, Part IV—Distribution.

### 3. Definitions

For the purposes of this guide, the following terms and definitions apply. *The Authoritative Dictionary of IEEE Standards Terms* [B29]<sup>3</sup> should be referenced for terms not defined in this clause.

**3.1 distributed resources (DRs):** Power sources such as generators, photovoltaic units, fuel cells, etc., connected on distribution circuits and dispersed throughout the utility distribution system.

**3.2 distribution automation:** A technique used to limit the outage duration and restore service to customers through fault location identification and automatic switching.

**3.3 interrupting medium:** The material used to facilitate the interruption of the arc during opening of a switching device.

**3.4 polarizing voltage:** The input voltage to a relay that provides a reference for establishing the direction of the operating current.

**3.5 sympathetic tripping:** The phenomena where an unfaulted interrupting device trips for a fault on a nearby circuit, usually caused by current inrush on the device after the faulted feeder's interrupting device opens and the system voltage returns to normal.

**3.6 varmetric relays:** Relays that respond to the quadrature (imaginary) component current compared to the polarizing voltage.

**3.7 wattmetric relays:** Relays that respond to the in-phase (real) component current as compared to the polarizing voltage.

## 4. Fundamentals

### 4.1 Fault characteristics

#### 4.1.1 Type and calculation

Faults occur on overhead and underground electric distribution systems with regularity. It is not feasible to design distribution systems to eliminate the possibility of faults from occurring. Faults can be caused by a number of sources including the following:

- Weather (such as wind, lightning, extreme temperature, and precipitation)
- Equipment failure
- Forestry contact
- Public contact (including pole and overhead contacts and underground dig-ins)

---

<sup>1</sup> IEEE publications are available from the Institute of Electrical and Electronics Engineers, 445 Hoes Lane, Piscataway, NJ 08854, USA (<http://standards.ieee.org/>).

<sup>2</sup> The IEEE standards or products referred to in this clause are trademarks of the Institute of Electrical and Electronics Engineers, Inc.

<sup>3</sup> The numbers in brackets correspond to those of the bibliography in Annex A.

- Animal contact
- Vandalism
- Vehicle accidents

When faults occur, they can present hazards to the general public and utility personnel, and can cause damage to distribution facilities. Protective systems are applied to sense short circuit conditions (faults), clear faults in a timely fashion, and limit the effects to the smallest practical portion of the distribution system.

Different types of faults can occur on distribution systems. The design of the grounding configuration of a given distribution system such as a three-wire ungrounded or four-wire effectively grounded system determines the short circuit characteristics associated with different types of faults. Fault types commonly experienced include the following:

- Three-phase
- Phase-to-phase
- Phase-to-ground or single-line-to-ground
- Two-phase-to-ground

Most faults are temporary in nature. Common causes of temporary faults are wildlife, wind, and lightning. Some faults are permanent in nature, such as those caused by equipment failures or dig-ins. Often, on distribution systems, faults can evolve from one type to another, such as a phase-to-ground fault flashing over and involving another phase. In some cases, the fault current magnitude will change through the course of the fault event as a fault arc is established or the item initiating the fault burns away. Simultaneous faults involving different distribution circuits, sometimes of different voltages or phase relationships, can also occur.

The type of grounding system and fault type must be understood in order to model and calculate fault currents, and to apply protective systems that will sense and operate for detectable fault conditions. There are three classes of grounding systems used. They include ungrounded, impedance (resistance or reactance) grounded, and effectively (or solidly) grounded. Current and voltage characteristics during fault conditions will differ from non-faulted conditions, and will vary depending on the grounding system utilized. Fault impedance should be considered. Some faults will be solid, such as the case when a broken phase conductor contacts a neutral wire; some will have an arc whose resistance varies with the arc length, such as an insulation flashover; and other faults involve a specific fault impedance, such as the case of a tree limb contacting an overhead circuit. Fault impedance is typically more of a consideration for faults involving ground, or at lower distribution voltages. In addition, the types of faults that may occur at a given location on a distribution system are defined by the number of phases (one, two, or three) in place.

Calculations of the system fault currents used to select, apply, and set protective devices for use on distribution systems are typically accomplished through the use of the symmetrical components methodology. Symmetrical components are a mathematical tool used to calculate the effects of balanced and unbalanced fault conditions on three-phase distribution systems. Most fault studies utilizing symmetrical components are performed through the use of computers and software tools that allow protection specialists to model three-phase power system impedance characteristics, and calculate short circuit currents or 'sequence components' for various types of fault conditions. These currents can then be used to select and apply protective devices such as relays, reclosers, and fuses. Various cases are typically modeled in order to calculate maximum and minimum fault currents. For radially designed and operated distribution circuits the maximum available fault current is at the substation bus or feeder source. Due to the effects of the impedance of the line conductors, fault currents decrease with distance from the substation source. In many cases, maximum fault currents are limited in order to apply distribution class equipment on the circuit.

### 4.1.2 High-impedance faults

In some cases, the fault impedance will limit the fault current to values that are not detectable or that are comparable to load current values. Examples of this condition include a dry tree limb contacting two phase conductors, or the case of a conductor breaking and contacting asphalt or concrete pavement. These conditions, typically referred to as high-impedance faults, present a challenge to the protection specialist in application of protective devices to sense and clear faults. Conventional overcurrent and distance protection cannot reliably detect this type of fault. Special protection is necessary for this type of fault, which is beyond the scope of this guide. In the last decade, there have been technological advancements in the development of protective and monitoring devices specifically designed to sense high-impedance faults. Evaluation of the trade-offs between security and dependability of these devices is continuing.

## 4.2 Load characteristics

It is important to have the knowledge of load characteristics at various points in a power system for various studies such as load flow, short circuit, stability, and electromagnetic transients as explained in “System load dynamics-simulation effects and determination of load constants” [B30], “Representation of loads” [B11], “Incorporation of load modeling in load flow studies” [B17], and “A fault locator for radial subtransmission and distribution lines” [B14]. Complex models to represent the load exist; however, the main problem to include adequate representation of loads is obtaining proper data for use in a model.

Although frequency-dependant load models have been proposed in various works such as “Representation of loads” [B11], “Incorporation of load modeling in load flow studies” [B17], and “The influence of load characteristics on power system performance—A C.E.G.B. viewpoint” [B63], it is difficult to obtain data from field tests for these models. It is almost impossible to obtain permission from grid control to isolate a part of the system and vary frequency over a wide range to measure load frequency characteristics at various load points. In a large interconnected system, the frequency usually does not vary over a wide range.

## 4.3 Harmonics and transients

### 4.3.1 Harmonics and their effect on distribution line protection

A harmonic is defined as a sinusoidal component of a periodic wave or quantity having a frequency that is an integral multiple of the fundamental frequency (see IEEE Std 519™-1993 [B38]). In other words, a harmonic is a sinusoidal waveform that has a frequency equal to an integer multiple of the fundamental frequency. For 60 Hz power systems, harmonics will be integer multiples of 60 Hz, which can be expressed another way, as follows in Equation (1):

$$h = n \cdot 60 \text{ Hz} \tag{1}$$

where

- $h$  is the harmonic frequency
- $n$  is the harmonic number

A 60 Hz waveform and its second, third, fourth, and fifth harmonics are shown in Figure 4-1.

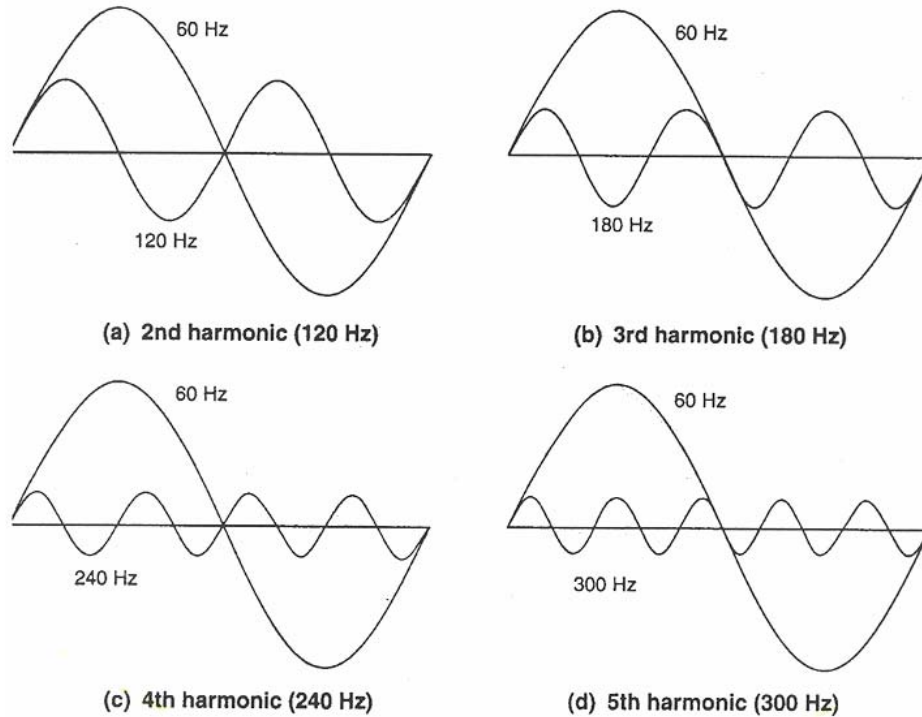

**Figure 4-1—Second, third, fourth, and fifth harmonics with a 60 Hz sinusoid  
from IEEE Std 141™-1993 (*IEEE Red Book*™) [B35]**

Nonlinear loads and power electronic devices are the largest source of the harmonics that appear in power systems. Some typical devices that inject harmonics into the power system are identified in *Electric Power Quality* [B27] as follows:

- Single-phase static and rotating ac/dc converters
- Three-phase static ac/dc converters
- High phase order static converters
- Battery chargers
- Electric arc furnaces
- Fluorescent lighting
- Pulse modulated devices
- Adjustable speed motor drives
- Transformers

Other power electronic devices such as diodes, silicon controlled rectifiers (SCRs), gate-turn-off (GTO) thyristors, and insulated gate bipolar transistors (IGBTs) chop the supply waveforms. This chopping effect produces non-sinusoidal waveforms, which contain harmonics. The harmonic producing device will act as a current source and inject harmonic current back into the system. This is counter-intuitive since we typically think of loads as absorbing power.

Like fundamental frequency currents, harmonic currents tend to flow towards the path of least impedance. This causes them to show up in the most unexpected places such as power system neutrals. Other problems such as series and parallel resonance can occur, but those problems will not be addressed in this guide.

The effect of harmonic currents on power system protection can be analyzed using symmetrical components. Assuming a balanced three-phase power system, harmonic quantities can be considered in terms similar to symmetrical components. However, a fundamental difference between the harmonic components and the symmetrical components is the frequency of the signal. Symmetrical components, as commonly used, are of fundamental frequency, while harmonic components have frequencies that are integer multiples of the fundamental frequency. Table 4-1 lists a few lower order harmonics and their corresponding similarity with a sequence component (see IEEE Std 141-1993 (*IEEE Red Book*) [B35] and “Representation of loads” [B11]).

**Table 4-1—Similarity between a harmonic quantity and a sequence component**

Order	Sequence	Order	Sequence	Order	Sequence
1	Positive	6	Zero	11	Negative
2	Negative	7	Positive	12	Zero
3	Zero	8	Negative	13	Positive
4	Positive	9	Zero	14	Negative
5	Negative	10	Positive	15	Zero

The similarity between a sequence component with any harmonic component can be found by further developing Table 4-1. For example, the 16<sup>th</sup> harmonic would be similar to the positive sequence; the 17<sup>th</sup> harmonic would be similar to the negative sequence, and so on.

Thinking of harmonics in terms of sequence components can aid the protection engineer in analyzing how harmonics might affect protection devices. For example, all harmonics divisible by three or *triplens* are similar to zero sequence quantities and are thus capable of affecting ground relays if the relays are not tuned to the fundamental frequency. Negative sequence harmonics may cause erroneous operation of negative sequence responding elements if those elements are not tuned to the fundamental frequency. Protective devices such as fuses and traditional electromechanical overcurrent relays monitor an unfiltered current, and thus respond to the *total RMS* value of the current. The effect of harmonics on these devices should be considered when high harmonic distortion is present. If harmonic distortion is great, the total RMS current can be significantly greater than the fundamental frequency component alone. The true RMS current can be found by using Equation (2) as follows:

$$\text{RMS} = \sqrt{\sum_{n=1}^{\infty} i_n^2} \quad (2)$$

where

- $i$  is the RMS value of a particular harmonic current
- $n$  is the harmonic number

It should be noted that harmonics associated with the acceptable distortion levels set forth in IEEE Std 519-1993 [B38] do not present a significant threat to the proper operation of protective relays. Furthermore, harmonic currents tend to affect electromechanical relays more severely than modern microprocessor-based relays. Most of these microprocessor relays employ 60 Hz filters in their protection algorithms and are practically immune to the effects of harmonics.

#### 4.3.2 Effect of transients on distribution line protection

Distribution line protective relays can be negatively affected by power transients, and their effect should always be evaluated when applying settings. For example, if a large capacitor bank is installed at the

substation bus, “close in” faults can cause large capacitor discharge currents to flow resulting in the possible misoperation of instantaneous over-current relays. Additional examples of transients are transformer energization inrush and system switching. Typically, time over-current relays are not affected by transients since the transient will be dampened out much faster than the relay operating time.

#### 4.4 Interrupting ratings

When circuit breakers, reclosers, and fuses are called upon to interrupt a fault, it is imperative that their interrupt rating is not exceeded. The interrupt rating is the maximum symmetrical current that the device is capable of interrupting.

When applied to reclosers and breakers, the interrupt current rating must be greater than the maximum expected symmetrical fault current at the device’s point of application. The X/R ratio at that location must be equal to or less than that at which the recloser is tested, at the maximum interrupting current, during the operating duty test. No uprating for symmetrical fault currents occurring at X/R ratios less than these maximums for which the recloser is tested should be allowed.

Typically, reclosers are rated up to 20 kA. Circuit breakers are rated up to 63 kA for distribution applications.

### 5. System configuration and components

#### 5.1 System

##### 5.1.1 Neutral treatment

As mentioned in 4.1.1, there are three main methods of system grounding used around the world. The methods are solidly grounded, ungrounded, and impedance grounded. The solidly grounded method can be uni-grounded or multi-grounded. Impedance grounded can be resistive grounded, reactive grounded, or resonant grounded. The grounding method used is not important during normal operation, if all the loads are connected phase-to-phase. However, during single-phase-to-ground faults, operational and safety aspects strongly depend on the grounding method chosen (see “Roundup: System grounding” [B52] and *Electricity Distribution Network Design* [B55]).

##### 5.1.1.1 Multi-grounded system

Multi-grounded systems have a neutral wire that is grounded at multiple locations along the length of the feeder. This is commonly referred to as a four wire system supplied by a wye-grounded source. This is the most widely used method in the U.S. and is also used in some developing countries. It provides power for single-phase and three-phase loads and is cost-effective for rural areas where single-phase loads are widely scattered. Phase-to-ground faults do not excessively affect voltage magnitudes on the other two unfaulted phases because the neutral is solidly grounded and shifts slightly since the grounding resistance in real life applications cannot be zero. Ground fault currents may be high, but the majority of fault current returns to the source through the neutral conductor, not through ground, which limits touch and step voltages within acceptable ranges. Ground fault currents depend on the system voltage, parameters of the feeder on which the fault occurs, and the grounding resistance. A system is considered effectively grounded if the voltage rise on the unfaulted phases does not exceed 35% of nominal voltage (see IEEE Std C62.92.4).<sup>4</sup> Ground fault protection is provided by ground overcurrent relays set more sensitively than phase overcurrent relays, depending on the load unbalance as explained in 5.1.1.2.

---

<sup>4</sup> Information on references can be found in Clause 2.

Advantages of multi-grounded systems are that the overvoltages during ground faults are low and protection is simple and inexpensive.

Disadvantages of multi-grounded systems are that the circuit should be quickly interrupted when ground faults occur to prevent the high fault currents from causing excessive damage, to prevent damage to unfaulted circuit components, and to minimize the duration of voltage dip to customers connected to the faulted phase.

### 5.1.1.2 Ungrounded system

Ungrounded systems (Figure 5-1) are still widely used. Since the neutral is not grounded, it can freely shift. Under normal conditions and balanced loads, phase-to-ground voltages are equal in magnitude and  $120^\circ$  apart. Therefore, there is no voltage difference between neutral and ground. In the case of a phase-to-ground fault (Phase C in Figure 5-2), the fault current will flow from the source to the fault location and returns through the stray capacitance-to-ground of the two unfaulted phases of that feeder and the unfaulted phases of all other feeders connected to the same power transformer. Therefore, ground fault current magnitudes depend not only on the faulted feeder parameters, but also on the size (i.e., stray capacitance) of the rest of the system. Magnitudes can be approximately calculated from Equation (3) (as shown in Figure 5-3).

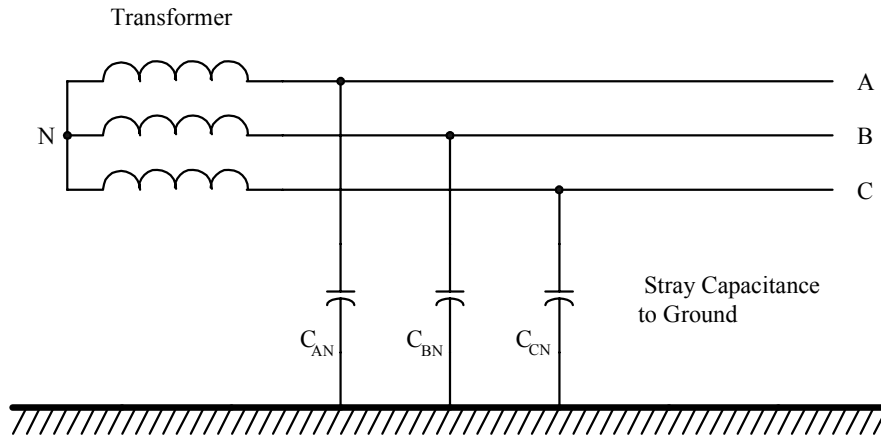

Figure 5-1—Ungrounded system

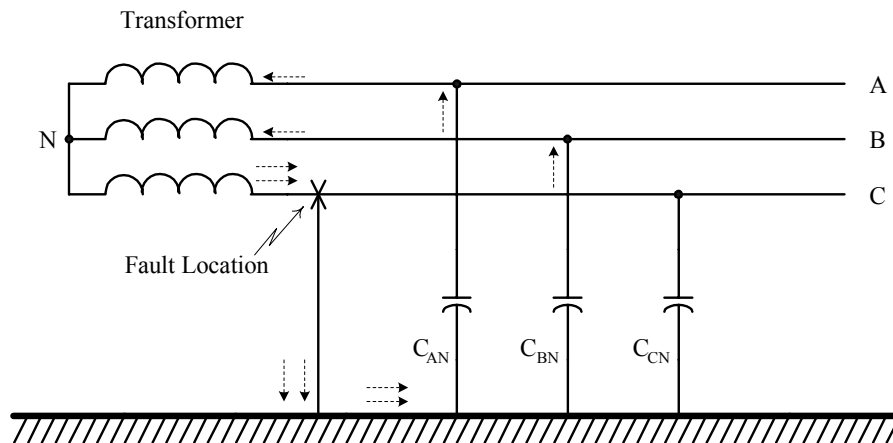

Figure 5-2—Ground fault in ungrounded system

$$C_{AN} = C_{BN} = C_{CN} = C \quad (\text{phase-to-ground capacitance of each phase})$$

$$|V_{AN}| = |V_{BN}| = |V_{CN}| = V_{PH} \quad (\text{phase-to-ground voltages})$$

$$I_A = j\omega CV_{CA}$$

$$I_B = -j\omega CV_{BC}$$

$$I_f = |\vec{I}_A + \vec{I}_B| = 3\omega CV_{PH} \quad (\text{fault current}) \quad (3)$$

where

$\omega$  is equal to  $2\pi f$  rad/s

Ground faults also cause phase-to-ground voltage rise on the unfaulted phases (A and B in Figure 5-3) approaching  $\sqrt{3} \times$  nominal. The insulation level of feeders should be designed to accommodate this voltage increase, which is a disadvantage due to increased investment. However, when system expansion increases the fault current through the stray capacitance, a neutral may be added, converting it to a grounded system. This can be accomplished by grounding the neutral of the transformer, either solidly or through an impedance, or by installing a grounding transformer. If the solidly grounded method is used, the same feeders can then transfer more power by increasing the system voltage. For example, feeders of an existing 10 kV system can be energized at 20 kV, since they are already designed for this higher voltage, allowing transfer of two times more power. This has been implemented in some countries in Europe.

Effective ground fault protection for ungrounded systems is provided by directional overcurrent relays that use residual voltage or neutral current for polarization and residual current from the faulted feeder, as described in 8.15. Phase difference between residual voltage and residual current is approximately  $90^\circ$  (Figure 5-3).

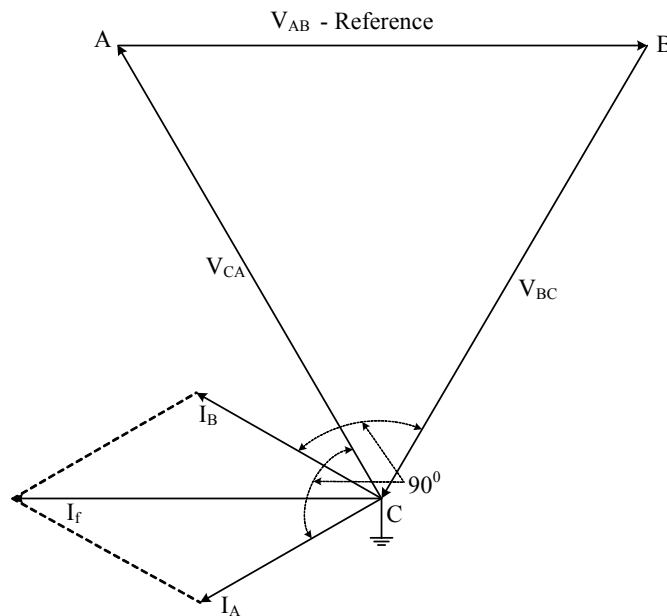

Figure 5-3—Voltage and ground fault currents in ungrounded system

The ungrounded system can operate for a prolonged time with a ground fault, and the arc can self-extinguish. This is an advantage for reliable operation, but also poses a personnel safety hazard. Relays should be applied to detect the condition and alert the operators so that the fault can be located and repaired in a timely manner.

A disadvantage of the ungrounded system is that fault current arcs cannot self-extinguish when capacitive currents become high. Also, intermittent arcing can occur and develop high-frequency oscillations that can cause overvoltage escalation of several times rated voltage. There will be fundamental frequency voltage rises on healthy phases; therefore single-phase-to-ground faults can develop into phase-phase faults; operating with a single-phase-to-ground fault can yield high fault currents similar to solidly uni-grounded systems in the case of a second phase-to-ground fault.

### 5.1.1.3 Uni-grounded system

Uni-grounded systems are solidly grounded only at the substation. This can be a three-wire system, with no neutral conductor (Figure 5-4) or a four-wire system with an insulated neutral. Ground-fault currents can be as high as phase-fault currents or even higher, similar to multi-grounded systems. However, ground fault currents flow back to the source through earth. A very high voltage between the faulted point and the reference ground ( $V_g$ ) can occur. Part of this voltage represents hazardous voltages defined as touch ( $V_{\text{touch}}$ ) and step ( $V_{\text{step}}$ ) voltages that are dangerous for humans and animals (Figure 5-5).

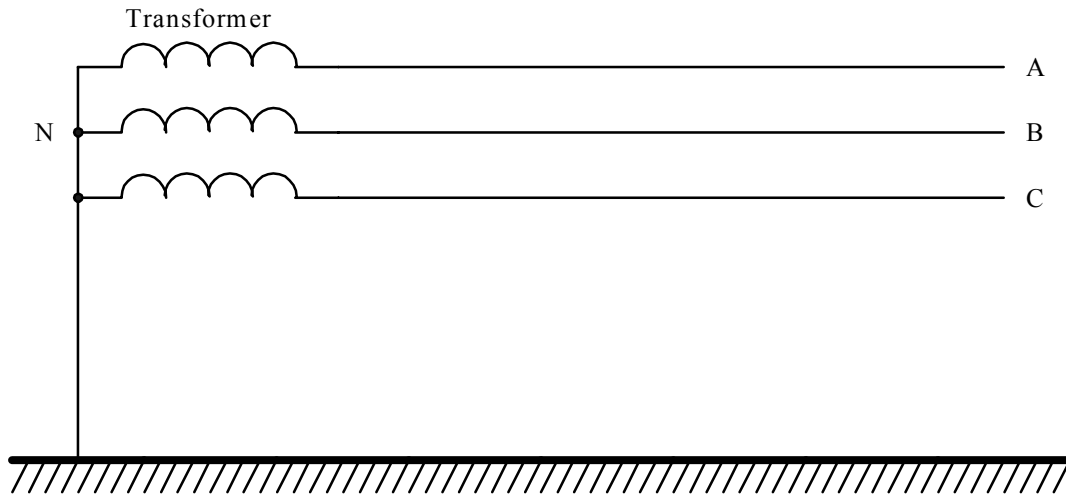

Figure 5-4—Solidly uni-grounded system

Advantages are that overvoltages are small (usually below 1.4 p.u.), and intermittent arc voltages are avoided. Because the transformer windings near the neutral do not see high voltages even during ground faults, this permits a graded insulation of the entire winding, which is less expensive.

A disadvantage is that extensive analysis is needed to design an effective grounding system.

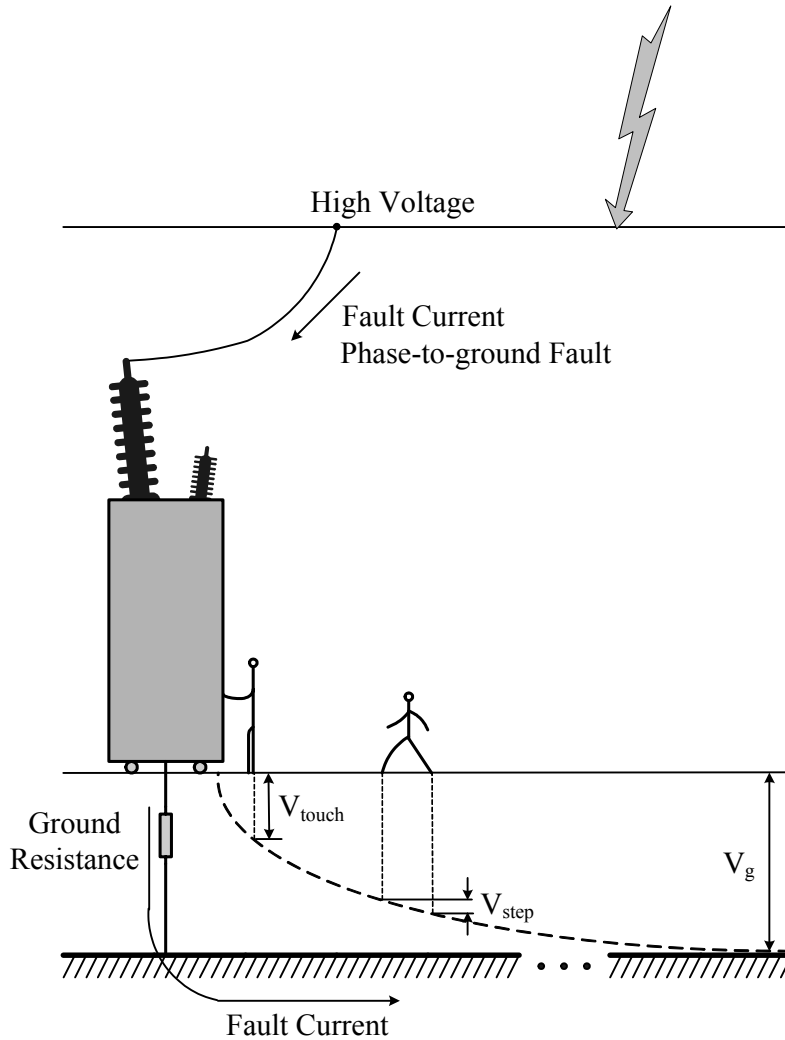

Figure 5-5—Touch and step voltages for a substation transformer

#### 5.1.1.4 Resonant-grounded system

Resonant-grounded systems are most often applied in Europe. In this method, the transformer neutral is grounded through a reactance, also known as a Petersen coil (Figure 5-6). The reactance is resonantly tuned to the fundamental frequency with the stray capacitance of all feeders connected to the same transformer. The value of reactance is approximately determined by Equation (4). In the case of a ground fault (C phase-to-ground fault in Figure 5-7), if properly tuned the neutral reactor and the system stray capacitance will cause the same amount of fault current to flow in opposite directions through the point of fault, canceling each other. Figure 5-7 illustrates fault current contribution by the system stray capacitance (solid-line arrows) and by the neutral reactor (dashed-line arrows). Since it is impossible to entirely match values for the neutral reactor with the system stray capacitance, a small amount of ground fault current will flow through the fault, but the majority of current will return to the source through the reactor. Small mismatches between the reactance and system capacitance (below 25%) will not create protection problems.

Advantages of a resonant-grounded system include the following:

- Ground fault currents are small.
- Arcs are self-extinguished.
- Touch and step voltages are small.
- Intermittent ground faults are avoided.

Disadvantages of a resonant-grounded system include the following:

- Phase-to-ground voltages can be high due to resonance.
- Arrester protective levels are higher.
- Insulation may need to be increased due to neutral shifting during transients.
- It is not effective in case of arcing cable faults.
- Cables can produce repetitive and harmful restrikes.
- Tuning can be difficult to adjust for varying system configurations such as those associated with distribution systems.

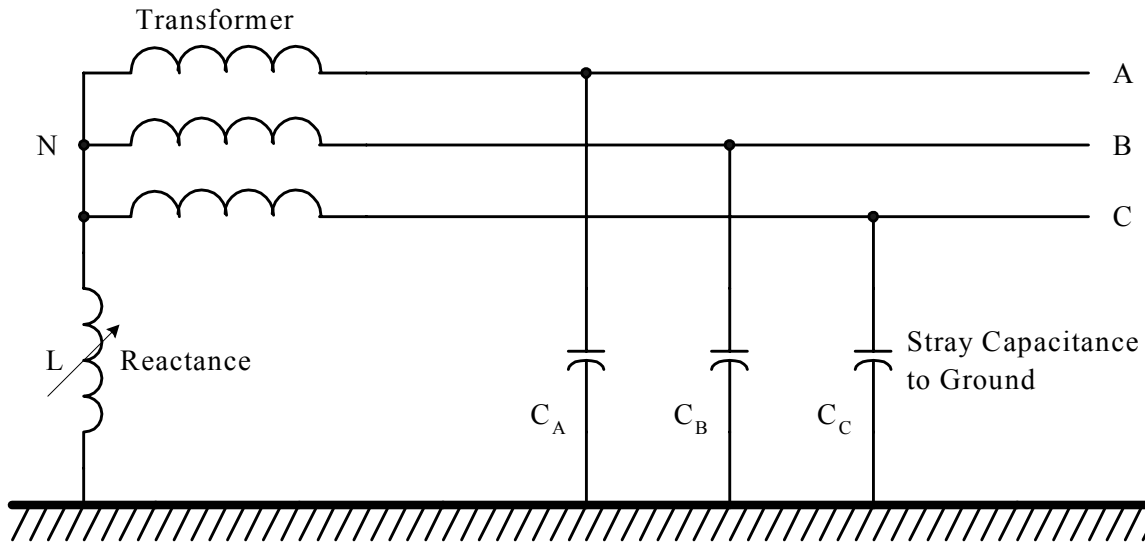

Figure 5-6—Resonant-grounded system

$$|I_L| = |\vec{I}_A + \vec{I}_B|$$

$$I_L = \frac{V_{PH}}{\omega L} = 3\omega C V_{PH}$$

$$L = \frac{1}{3\omega^2 C} \tag{4}$$

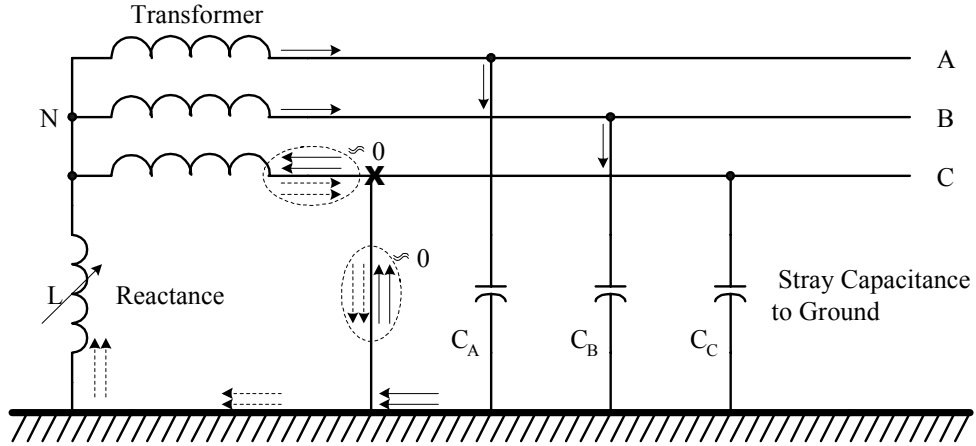

Figure 5-7—Ground fault in resonant-grounded system

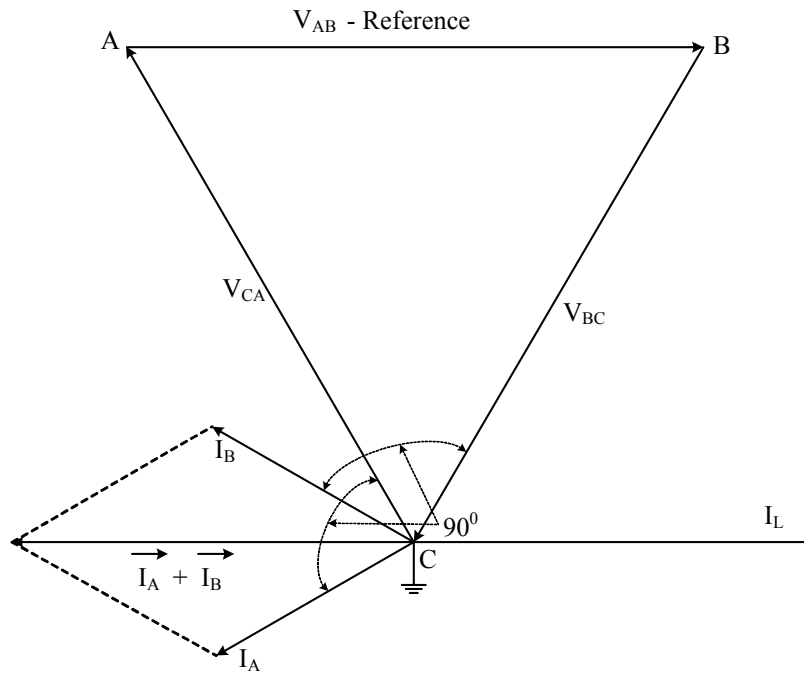
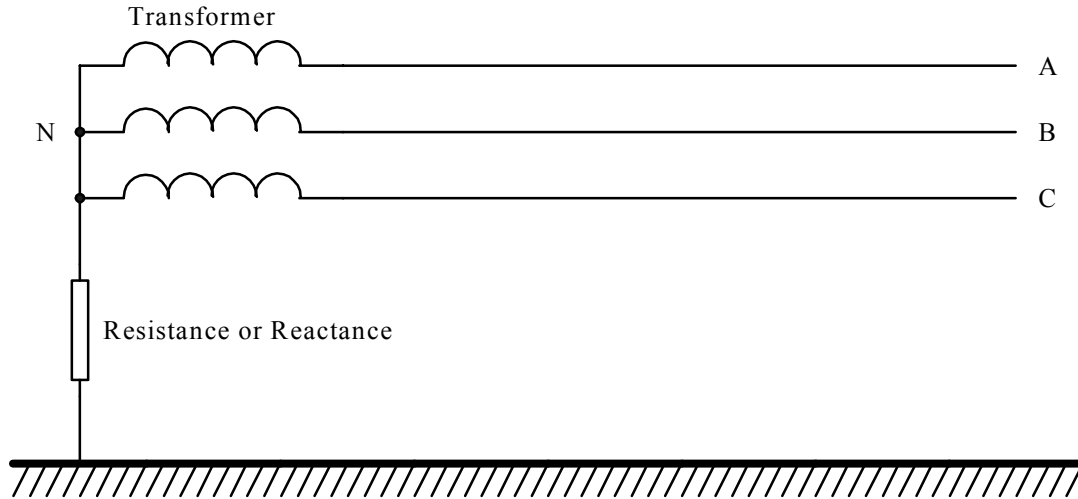

Figure 5-8—Voltages and ground fault currents in resonant-grounded system

### 5.1.1.5 Resonant-grounded system

To limit ground fault currents and reduce dynamic and thermal stress on equipment (particularly transformers), resistors or reactors are installed from the transformer's neutral to ground (Figure 5-9). However, this grounding method causes the neutral voltage to increase during ground faults. For a 40% reduction in ground-fault current using a resistor compared to fault current without a resistor, the neutral voltage increases to 80% of the phase voltage.

For this type of neutral grounding, resistors or reactors are used to reduce ground fault currents to acceptable levels, but not to entirely (almost zero current) eliminate it as with resonant-tuned systems.



**Figure 5-9—Resistively or reactively grounded system**

Advantages of resistive or reactive grounded systems include the following:

- Ground-fault currents, touch, and step voltages are reduced.
- Overvoltages are smaller compared to ungrounded systems.
- Intermittent arc voltages are avoided.

Some disadvantages of these systems include the following:

- The use of neutral resistance or reactance increases neutral voltages during ground faults and requires higher insulation of the transformer neutral.
- Overvoltages can be high when higher resistance values are used.

Table 5-1 presents comparative results of the impact of different transformer neutral treatments on a typical distribution system during phase-to-ground faults. Figure 5-10 shows a 12.47 kV feeder supplying power to a 5 MVA constant impedance, delta connected load. The source voltage was increased 5% to obtain 0.99 p.u. voltage at the load. A ground fault on phase C, with a fault resistance of 1 Ω, was simulated. For different load types and connections, the results will be different.

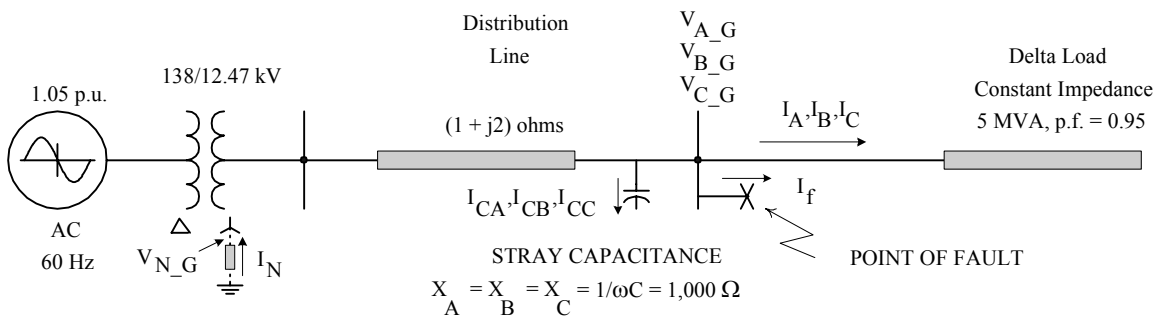

**Figure 5-10—A typical distribution system with a radial feeder**

**Table 5-1—System voltages and currents during single-phase-to-ground faults for different neutral treatments**

Neutral impedance ( $\Omega$ )		Normal operation	Single-phase-to-ground fault (refer to Figure 5-10)				
			Solidly grounded	Ungrounded	Resonant grounded	Resistor grounded	Reactor grounded
			0.1 $\Omega$	10 000 $\Omega$	1 000/3 $\Omega$	10 $\Omega$	10 $\Omega$
Voltage at fault	$V_{AG}$ [V]	7 159	7 276	12 430	12 400	10 480	11 610
	$V_{BG}$ [V]	7 163	7 252	12 480	12 400	11 860	10 580
	$V_{CG}$ [V]	7 161	2 062	22	0	578	542
Load currents	$I_A$ [A]	230	114	231	230	212	198
	$I_B$ [A]	230	223	231	230	238	219
	$I_C$ [A]	230	190	230	230	213	226
Xformer neutral	$V_{NG}$ [V]	0	207	7 197	7 141	5 795	5 601
	$I_N$ [A]	0	2 067	0	21.4	579	560
Fault current	$I_f$ [A]	0	2 062	22	0	578	542
Capacitive currents	$I_{CA}$ [A]	7.2	7.3	12.4	12.4	10.5	11.6
	$I_{CB}$ [A]	7.2	7.3	12.5	12.4	11.9	10.6
	$I_{CC}$ [A]	7.2	2.1	0	0	0.6	0.5

### 5.1.2 Fault studies

In the application of overcurrent protective equipment to distribution systems, it is important to know the minimum as well as the maximum fault current levels. A fault study should be performed to obtain these levels at each node of the circuit.

For a radial system, maximum fault current levels are influenced by low source impedances at maximum generation conditions and zero fault impedance. Minimum fault-current levels are influenced by high source impedances during times of minimum generation and non-zero fault impedance (Figure 5-11). These conditions are calculated for three-phase, line-to-line, and line-to-ground faults. Normally, fault current decreases as the fault resistance increases. However, there are actual circuits where the current magnitude in one phase of a double-line-to-ground fault will increase when going from a zero to a non-zero value of fault impedance (see *Electrical Distribution-System Protection* [B12]).

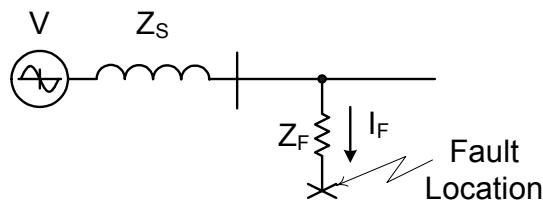

**Figure 5-11—Fault on radial system**

It is common in fault studies to use nominal system voltages with no distinction between circuit loading conditions that produce maximum and minimum voltages. Also, it is assumed that loads are not modeled. In most distribution applications, the substation transformer impedance is much larger than the generation-source impedance supplying it. For this reason, the maximum and minimum generation source impedances are often assumed to be equal. In locations served by parallel transformers, minimum fault currents occur with only one transformer in service.

### 5.1.2.1 Methods for calculating source impedance

Depending on the information available, several methods for calculating source impedance may be used.

In radial systems, the positive-sequence source impedance is the sum of the positive sequence impedances of all system components from the distribution substation low-voltage (LV) bus up to and including the generator. The negative sequence source impedance is defined in a similar fashion. The zero-sequence source impedance is usually not the sum of the component zero-sequence impedances because of the effect of the transformer connections.

If a short-circuit study was performed and the per-unit values of fault current for a three-phase fault ( $I_{f_{3ph}}$ ), line-to-line fault ( $I_{f_{ph-ph}}$ ), and line-to-ground fault ( $I_{f_{ph-G}}$ ) at the high-voltage (HV) bus of the distribution substation were determined, symmetrical components  $Z_{S1}$ ,  $Z_{S2}$ , and  $Z_{S0}$  of source impedances at the HV bus can be found from Equation (5), Equation (6), and Equation (7), as follows:

$$Z_{S1} = \frac{V_{l-n}}{I_{f_{3ph}}} - Z_f \quad (5)$$

$$Z_{S2} = \frac{j\sqrt{3}V_{l-n}}{I_{f_{ph-ph}}} - Z_{S1} - Z_f \quad (6)$$

$$Z_{S0} = \frac{3V_{l-n}}{I_{f_{ph-G}}} - Z_{S1} - Z_{S2} - 3Z_f \quad (7)$$

Knowing that transmission lines and transformers have  $Z_1 = Z_2$  and assuming  $Z_f = 0$ , then for single- and three-phase faults, the source impedances  $Z_{S1}$ ,  $Z_{S2}$ , and  $Z_{S0}$  can be calculated using Equation (8), Equation (9), and Equation (10) as follows:

$$Z_{S1} = \frac{V_{l-n}}{I_{f_{3ph}}} \quad (8)$$

$$Z_{S2} = Z_{S1} \quad (9)$$

$$Z_{S0} = \frac{3V_{l-n}}{I_{f_{ph-G}}} - 2Z_{S1} \quad (10)$$

The  $Z_{S1}$ ,  $Z_{S2}$ , and  $Z_{S0}$  values obtained from the Equation (8), Equation (9), and Equation (10) are HV bus values and have to be appropriately combined with the per-unit symmetrical components of the substation transformer to obtain the source symmetrical components at the LV side of the substation.

If only the three-phase fault kVA available at the HV bus is given, then the value for  $Z_{S1}$  magnitude is calculated by converting the fault kVA to a per-unit fault current magnitude, using Equation (11) and assuming a nominal system voltage if the actual line-to-line value of V at the HV bus is unknown. The per-unit magnitude of  $Z_{S1}$  can also be found from Equation (11) as follows:

$$|Z_{S1}| = \frac{V^2}{\frac{kVA_{3ph(FAULT)}}{kVA_B}} = \frac{V^2}{kVA_{3ph(FAULT_{pu})}} \quad (11)$$

where

$ Z_{S1} $	is the magnitude of positive-sequence source impedance (per unit)
$V$	is the line-to-line voltage at the substation HV bus (per unit)
$kVA_{3ph (FAULT)}$	is the available three-phase fault kilovolt-ampere
$kVA_B$	is the base kilovolt-ampere
$kVA_{3ph (FAULT)pu}$	is the three-phase fault kilovolt-ampere (per unit)

### 5.1.3 Fault impedance

Fault impedance ( $Z_f$ ) is the impedance involved in the fault (see *Electrical Distribution-System Protection* [B12]).  $Z_f$  is different than positive- ( $Z_1$ ) or zero-sequence ( $Z_0$ ) impedances, which are system characteristics.  $Z_f$  is an impedance, resistive or reactive, between the faulted power system phase conductor(s) or between phase conductors and ground.  $Z_f$  is not earth resistivity or the mutual impedance between an overhead conductor and a conducting ground plane.  $Z_f$  depends on the fault type and the environment. A line-to-line fault on an overhead circuit caused by a dry tree branch can be a high-impedance fault, and ground is not involved at all. A fallen conductor can cause a low  $Z_f$  value if the conductor drops into a stream or ground water, or it can cause a high  $Z_f$  value if it drops onto a dry pavement.

$Z_f$  is also a time variable. A fault may begin as a high-impedance fault and progress to a low impedance fault. Conversely, a fault may start out with some fault impedance that increases to infinity if the fault is self-clearing.

A number of different practices are used to determine minimum ground fault settings that will allow for fault impedance. Some of these practices are noted as follows:

- Select a percent value of the bolted single phase-to-ground fault at the end of the protected area.
- Use an established value for  $Z_f$  added at the end of the protected area. Frequently used values range from 0  $\Omega$  to 40  $\Omega$ .
- Set  $Z_f$  to a value that provides a minimum fault current equal to the continuous current carrying capability of the conductor. Fault currents below the thermal limit of the conductor may not be detected.
- Use a percent of three-phase fault currents.

### 5.1.4 Bus configurations

The bus configuration designs take into consideration requirements such as load characteristics, the necessity for maintaining continuity of service, flexibility of operation, maintenance, and cost. The designs vary from the simplest single-circuit layout to the involved duplicate systems installed for metropolitan service where the importance of maintaining continuity of service justifies a high capital expenditure.

Bus configuration for distribution buses may differ radically from the layout of transmission buses. In some metropolitan developments supplying underground cable systems, segregated-phase layouts are employed to secure the maximum of reliability in operation (see *Electrical Transmission and Distribution Reference Book* [B2]).

The following are some commonly used distribution substation bus arrangements and a description of the protective relay issues that these bus arrangements create.

Figure 5-12 shows a substation with a fused transformer, transformer secondary breaker (T), and three feeder breakers (F). The transformer secondary breaker provides bus protection and backup for the feeder breakers. Overcurrent relays on the transformer secondary breaker should be set below the transformer damage curve. Overcurrent relays on the feeder breakers should be set to coordinate with the transformer secondary relays and with downstream devices on the feeder. In this substation, there are two sets of relay curves to coordinate between the primary fuse and devices on the feeder. In some installations, the secondary breaker is omitted; then bus protection and feeder backup protection should be provided by the transformer fuse.

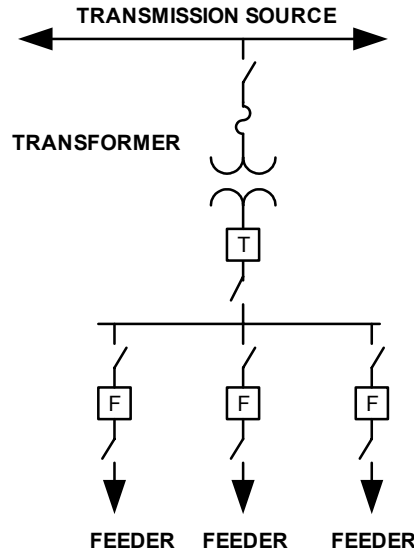

Figure 5-12—Single transformer distribution bus

Figure 5-13 shows a similar substation with a second transformer, a bus tie breaker (B), and additional feeders. Time overcurrent relays on the bus tie breaker should be coordinated with relays on the transformer secondary breakers and the feeder relays. This means there are three sets of relay curves to coordinate between the primary fuse and devices on the feeder.

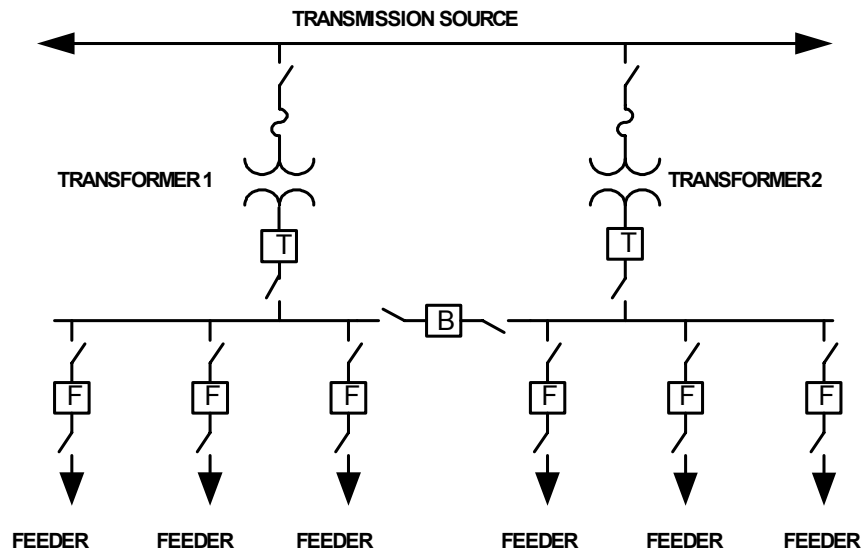
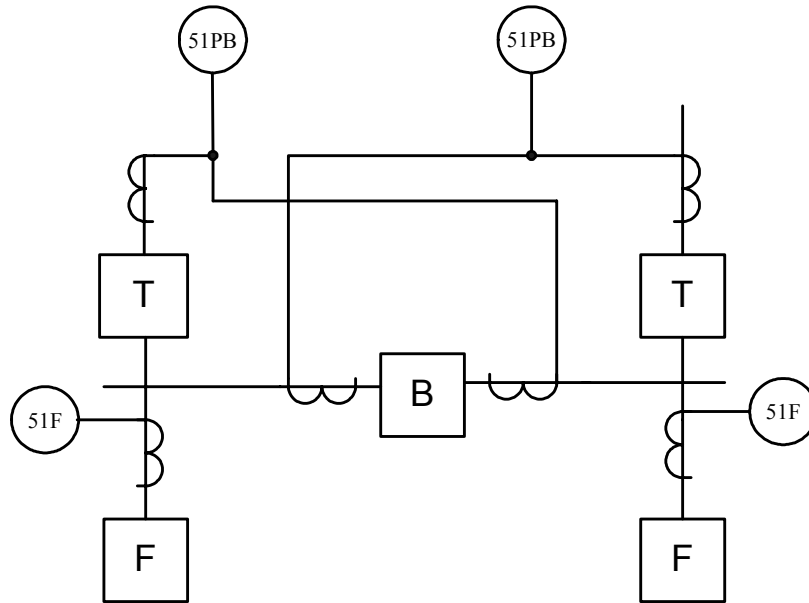

Figure 5-13—Two-transformer distribution bus

To add a bus tie breaker without introducing an additional set of time overcurrent relays, a fairly common scheme is the 'partial bus differential' scheme shown in Figure 5-14. This uses one relay (51PB) for each bus, connected to current transformers (CTs) on the transformer secondary breaker and on the bus tie breaker. The CTs are connected so each 51PB relay responds only to current on the associated bus.



**Figure 5-14—Partial bus differential scheme**

Figure 5-15 shows a main-bypass bus arrangement with high side power fuses for transformer overcurrent protection. Since there is no low side breaker on this transformer, the fuses are also the primary protection for the low side bus. The transformer, all of the feeder breakers (F), and the spare breaker (S) are normally connected to the main bus. Depending on the transformer winding configuration, the transformer fuses may have less current flowing through them for a low side bus fault than the turns ratio of the transformer indicates. For a delta-wye with the neutral of the wye-grounded, the transformer fuse will experience only the positive and negative sequence current for a phase-to-ground fault on the bus. This configuration desensitizes and slows the response of the fuses for ground faults on the bus and the feeders. The protection on the feeder breaker should be time-coordinated with the transformer fuses for faults on the feeders so the fuse should be slow enough to coordinate for phase-to-phase faults on the feeders. The spare breaker is used to energize the bypass bus. To take a feeder breaker out of service and keep the feeder energized, the normally open bypass switch is closed connecting the feeder to the bypass bus. The feeder breaker is then opened and isolated with the breaker disconnect switches. The feeder connected to the bypass bus is protected with the relays on the spare breaker. The protection on the spare breaker should be configured to protect and coordinate with the devices on the different feeders.

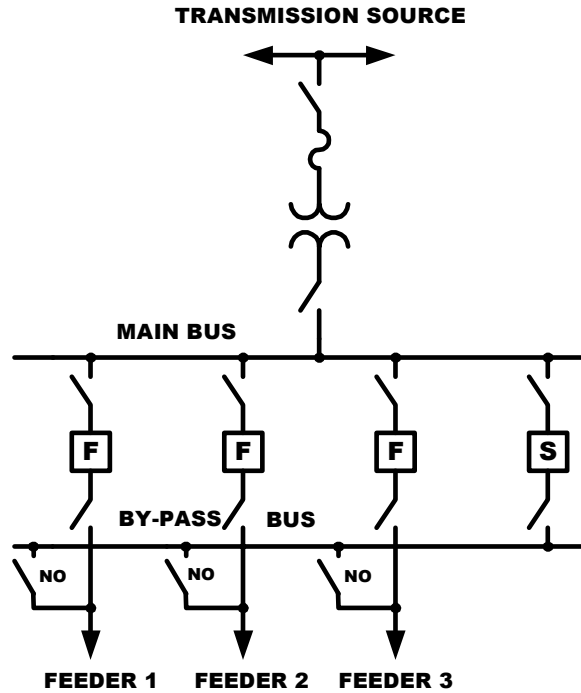

Figure 5-15—Main-bypass bus

Figure 5-16 shows a similar substation bus arrangement but with a breaker or circuit switcher equipped with protective relays on the high side of the transformer instead of fuses. If overcurrent relays are connected to CTs on the low side of the transformer and these relays trip the high side fault interrupter, the protection problem of the lack of sensitivity and speed of operation for bus and feeder phase-to-ground faults, that the fuses had, is eliminated.

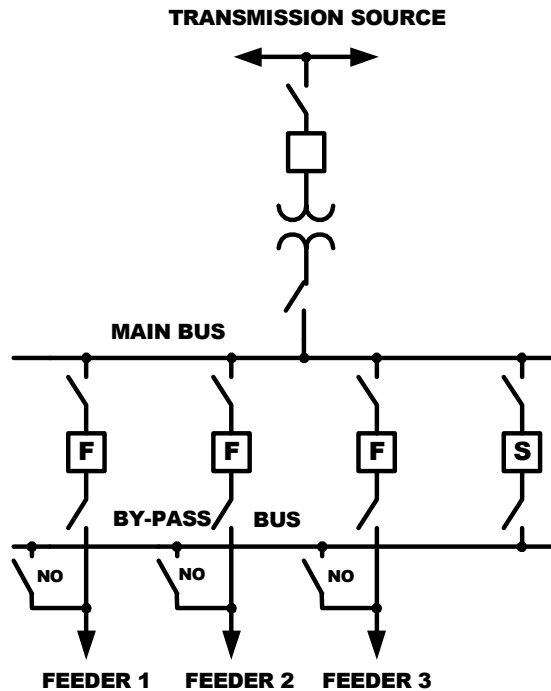

Figure 5-16—Main-bypass bus with high side interrupter

Figure 5-17 is of a substation bus arrangement that uses more air break switches but has additional flexibility of operation over the main-bypass bus arrangement. This bus arrangement is sometimes referred to as a dual-operation bus. The transformer and the feeder breakers can be connected to either bus. The B breaker is connected between the buses and is normally called a bus tie breaker. Although the feeder breakers can be fed off either of the buses, only Bus 2 can be used as a bypass bus. To bypass a feeder breaker, the transformer is connected to Bus 1, and the feeder to have the breaker removed from service is connected to Bus 2 through the normally open bypass switch. The feeder load is then carried through the bus tie breaker. The relay settings on the bus tie breaker need to be flexible enough to protect and carry the load of any of the feeders.

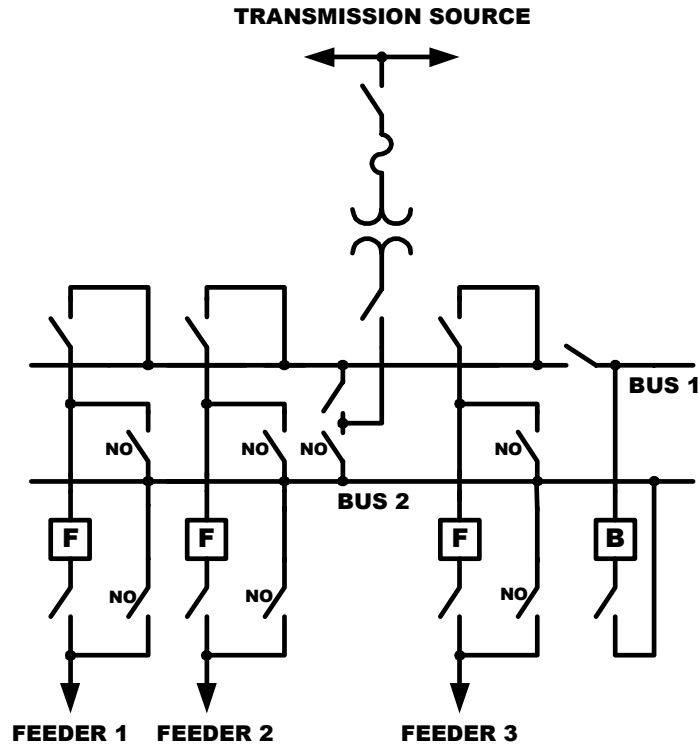

Figure 5-17—Dual-operation bus

The flexibility of the dual-operation bus is more obvious when there are two transformers to be operated either in split bus or parallel operation as shown in Figure 5-18. In this case, each transformer is connected to a different bus with some of the feeder breakers connected to each bus. If the transformers are to be operated in parallel, the bus tie is closed tying the two buses together. The coordination of the transformer high side protection, the bus tie breaker, and the feeder breakers is a little more complex. Depending on which bus the faulted feeder is connected to, the coordination is different. The complexity increases if the two transformers are not the same size, but it can be accomplished. As an example, using the bus configuration in Figure 5-18 for a fault on Feeder 1, the Feeder 1 relays will need to coordinate with the Transformer 1 fuse based on the current that Transformer 1 contributes to the fault. The Feeder 1 relays also need to coordinate with the bus tie relays for the current that Transformer 2 contributes to the fault. Also, the bus tie relays need to coordinate with the Transformer 2 fuse on the basis of the turns ratio of the transformer and the configuration of the winding of the transformer.

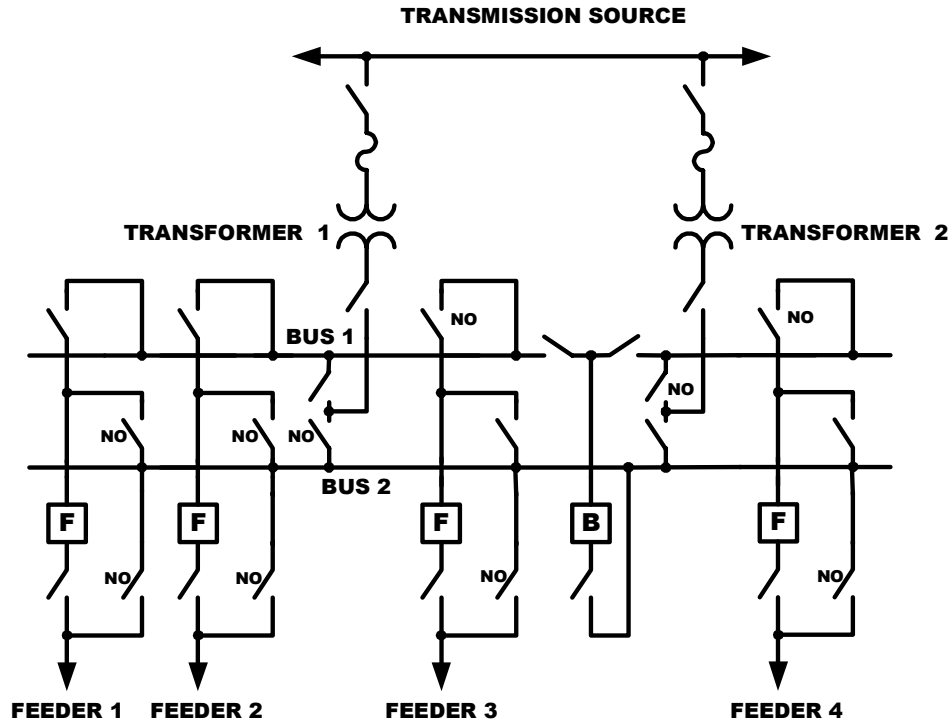

Figure 5-18—Dual-operation bus with two transformers

With this bus arrangement, if a feeder breaker is to be bypassed, it is best to put the transformers in split bus mode by opening one of the switches on Bus 1. This creates three buses. One transformer is connected to the left Bus 1 and the other to the right Bus 1. The bus tie breaker needs to be connected on the side with the feeder breaker to be bypassed. The feeder breakers are all connected to Bus 1. Bus 2 is then a bypass bus, and the feeder to have the breaker removed from service is connected to Bus 2 through the normally open bypass switch.

Figure 5-19 is of the main-bypass bus arrangement with two transformers. Low side transformer breakers (T) are added, which is the best arrangement to operate two transformers with this type of bus arrangement. If both transformers are in service, the transformers are operated in parallel. If only overcurrent relays are applied, there is a problem in coordinating the low side breaker relays to operate only the T breaker on the side with the faulted transformer. The application of differential or directional relays will correct this problem. For feeder faults, the overcurrent relays on the T breakers need to be coordinated with the feeder breaker overcurrent relays for the worse case, which is when only one transformer is in service.

With increased interest in distributed resources (DRs), it may be desirable to connect one or more generators to a distribution substation bus or feeder. Figure 5-20 shows one generator directly connected to a common bus with four feeders. However, DR can also be connected to the bus or feeder through an interface transformer. Higher reliability and flexibility can be provided by a double bus system and corresponding switching equipment. The scheme designs depend on the degree of operational flexibility and cost.

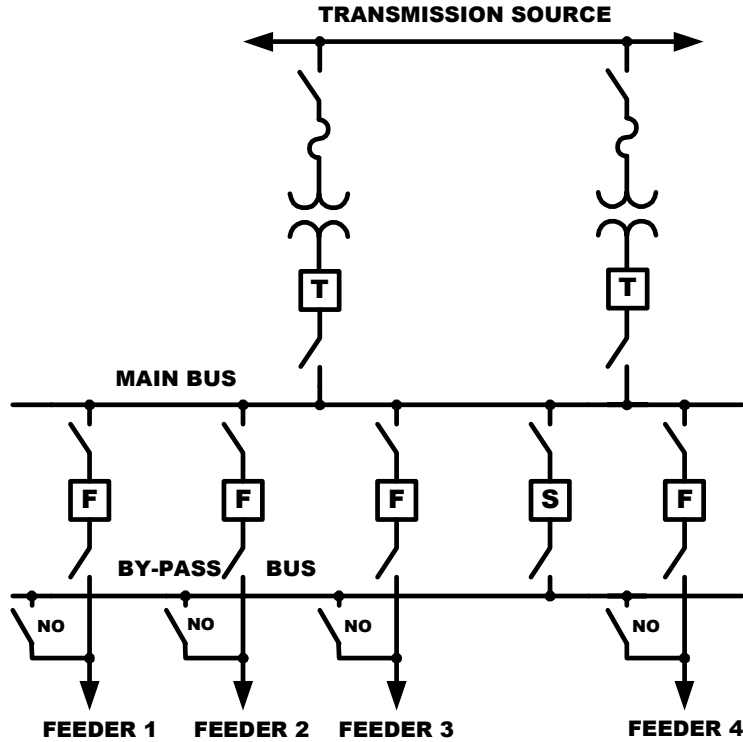

Figure 5-19—Main-bypass bus with two transformers

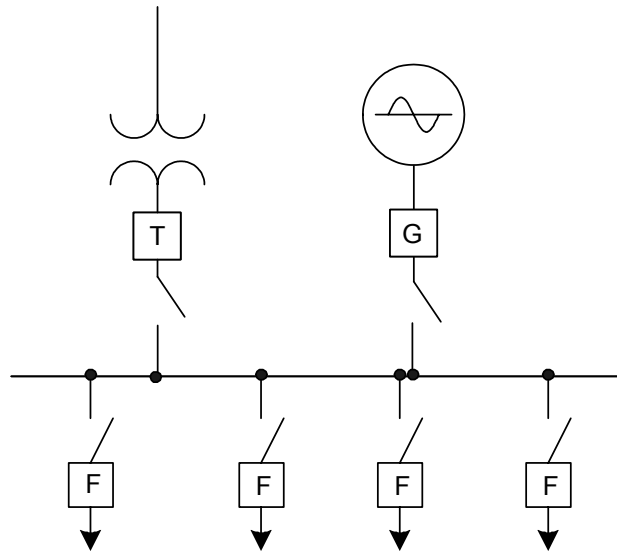

Figure 5-20—A generator connected to distribution substation bus

When a DR is connected to a bus or feeder, three different scenarios should be considered to estimate fault currents: 1) the utility system alone; 2) the combined utility and DR system; and 3) the DR alone. Although the DR would not normally be connected to the distribution system without the utility source, this can occur due to sequential tripping during a fault. It should be checked that by adding DRs the equipment capabilities would not be exceeded. If DR capacity connected to a bus is large, to limit its current contribution during faults, it may be necessary to use current-limiting reactors in series with each generator.

Proper protection operation and coordination on the utility system should not be impacted by the DR. For DR interconnection to distribution systems, see IEEE Std 1547™-2003 [B40].

#### 5.1.4.1 Bus configurations at generator voltage levels

Several examples of bus configuration schemes supplying feeders at generator voltage levels are shown in Figure 5-21.

Part (a) of Figure 5-21 shows several feeders connected to a common bus fed by only one generator. When the bus, generator breaker, generator, or power source is out of service for any reason, all feeders are simultaneously disconnected. Each feeder has a circuit breaker and a disconnect switch.

Part (b) of Figure 5-21 shows designs with more than one bus. High reliability and flexibility are provided by double bus systems and switching equipment. The scheme designs depend on the degree of operational flexibility required and budget constraints.

If generating capacity connected to a bus is large, it may be necessary to use current-limiting reactors in series with each generator or in series with each feeder, and sometimes both are required. In addition, bus-tie reactors may be used to keep the short-circuit currents within the interrupting ability of the breakers. Bus-tie reactors may be bypassed when one or more generators are out of service to prevent voltage and phase-angle differences between bus sections that would exist with the supply to a bus section through a reactor.

Figure 5-22 shows a design where continuous supply to all feeders is provided through reactor ties to a synchronizing bus in case one generator fails. Bus-tie circuit breakers are provided to tie adjacent bus sections for operation with one or more generators out of service. If needed, tie feeders from other stations can be connected to the synchronizing bus.

A typical bus configuration design also includes the following:

- Voltage transformers (VTs) and CTs to provide inputs for metering, control, and protection systems
- A ground bus to provide grounding for each feeder when it is out of service for safety to personnel
- Firewalls between bus sections or between each group of two bus sections to prevent a fire from spreading from one section to the adjacent sections

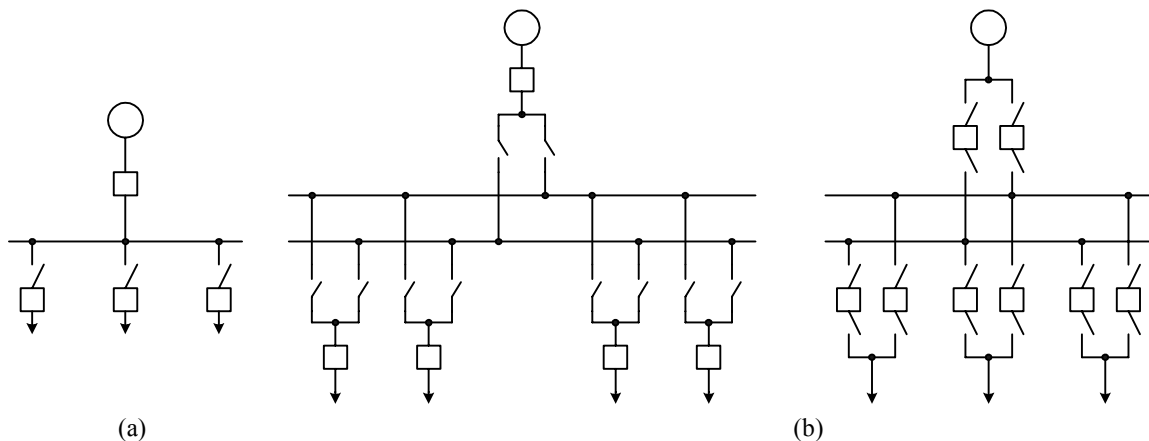

**Figure 5-21—Examples of bus configurations at generator voltage levels with one or two buses**

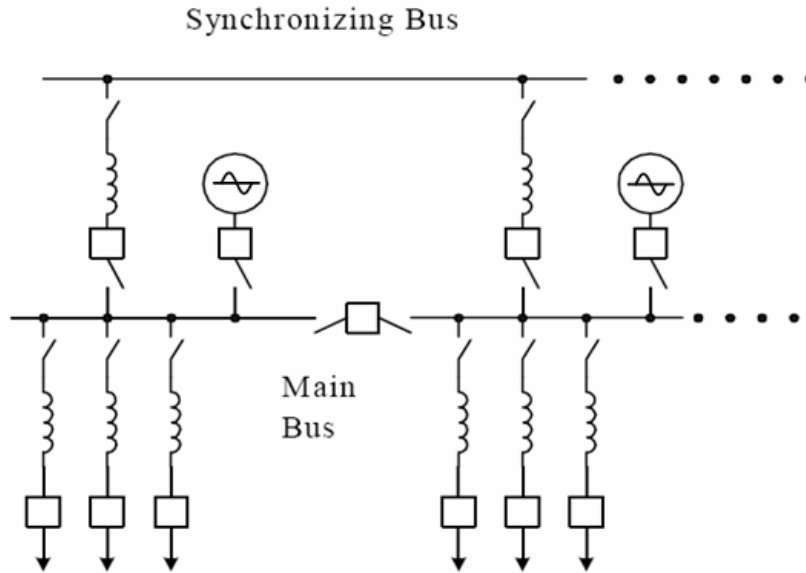
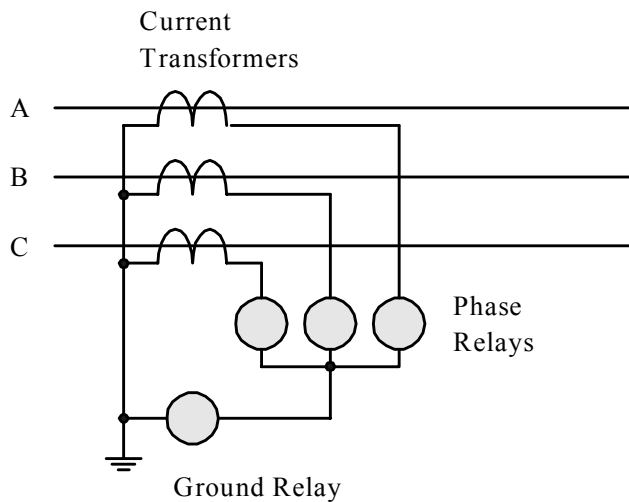

**Figure 5-22—Bus configurations at generated voltage levels with reactors and synchronizing bus**

### 5.1.5 Neutral versus residual ground CTs

#### 5.1.5.1 Ground-fault relaying

In power systems, ground-fault protection can be designed using ground relays. Figure 5-23 shows typical CT, overcurrent phase relay, and residual ground relay connections.

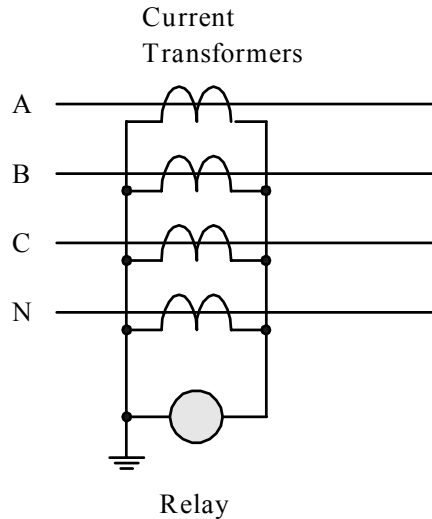

**Figure 5-23—Typical phase and ground relay connections**

Overcurrent relays used for ground-fault protection generally are the same as those used for phase-fault protection, except that a more sensitive range of minimum operating current values is needed.

When this method is used on four-wire multi-grounded systems, the ground relay setting should allow for the system unbalanced (residual) currents, resulting from the line-to-neutral connected loads.

Ground relays can be set more sensitively if the relays are not influenced by the load currents and the system unbalance. On four-wire systems with insulated neutral conductor, an additional CT installed in the neutral conductor removes the residual load currents from the ground relay (Figure 5-24). This application is most common in low-voltage systems.



**Figure 5-24—Ground relay and residually connected CTs**

When used in ungrounded systems, a polarizing signal (voltage or current) is also required to obtain directionality of protection operation.

Residually connected CTs can cause nuisance operation due to errors arising from CT saturation and unmatched characteristics. Sometimes the optimum relay speed and sensitivity are compromised because of this issue.

#### **5.1.5.2 Zero-sequence CT (core balance)**

An improved type of ground-fault protection can be obtained by a zero-sequence relay scheme in which a single window-type CT is mounted to encircle all three-phase conductors, as illustrated in part (a) of Figure 5-25.

When used on four-wire systems with insulated neutral conductors, the neutral conductor must pass through the zero-sequence CT as shown in part (b) of Figure 5-25.

There are several advantages of using zero-sequence CTs instead of residually connected CTs as follows:

- a) Only one CT is required for residual current measurements instead of three residually connected CTs.
- b) Zero-sequence CTs are more accurate since they measure true residual currents as a result of sums of flux produced by all three phases, while in residually connected CTs any mismatch in the CT characteristics will appear as false residual currents.
- c) Zero-sequence CTs can be more compact, having smaller core dimensions than residually connected CTs since they are not influenced by load currents or three-phase fault currents.
- d) During multi-phase faults, one or more residually connected CTs can saturate and cause false residual current through the relay.

Zero-sequence CTs are available in various designs, e.g., for mounting over a cable close to the cable termination or for installation around three phases in medium voltage switchgear. Zero-sequence CTs can be closed-core designs when cables can be disconnected for the CT installation or split-core designs for easier installation on existing cables.

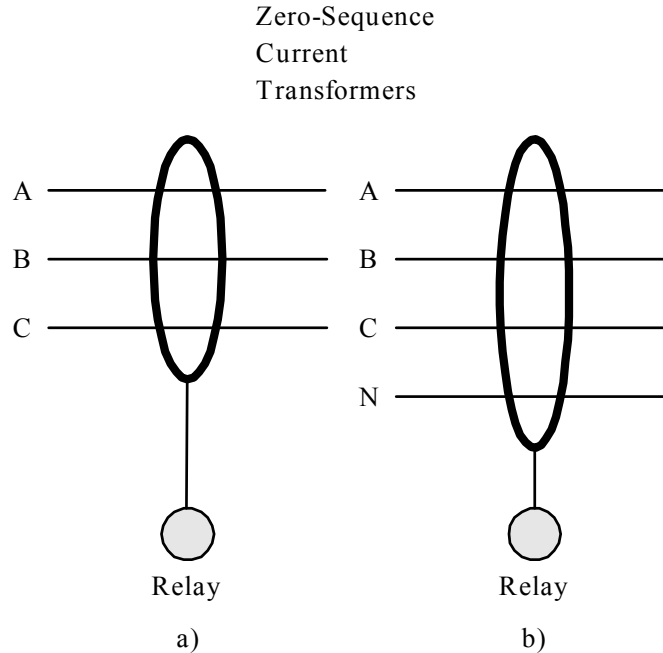

**Figure 5-25—Zero-sequence CT and ground relay, (a) three-wire system and (b) four-wire system**

When applied on cables with sheaths, to compensate residual currents that can flow through sheaths, grounding of cable sheaths must be done as shown in Figure 5-26. Any flux caused by residual currents in the cable sheath will be cancelled by the flux from currents through the sheath-grounding conductor.

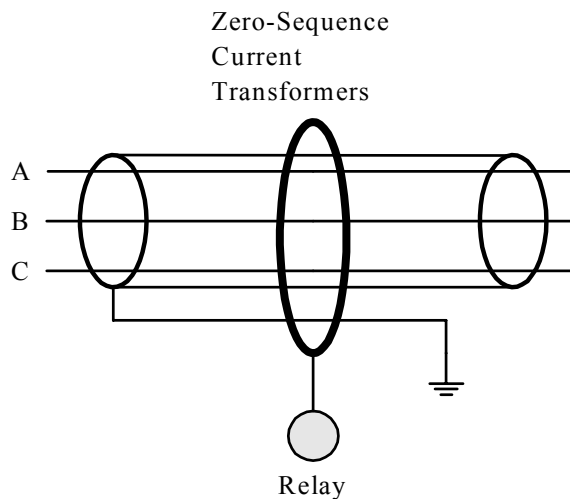

**Figure 5-26—Application of a neutral CT to a cable with sheath**

### 5.1.6 Transformer ground source connections

Additional transformers may be added to provide a ground reference on systems where no ground connection exists. A delta connected transformer is one example of this situation.

Two commonly used transformer arrangements are as follows:

- Grounded-wye with closed delta [part (a) of Figure 5-27]
- Zigzag [part (b) of Figure 5-27]

Both connections have high positive-sequence impedance, but low zero-sequence impedance. The zigzag transformer is more commonly used since it provides more effective use of transformer material. To limit ground-fault currents to a level satisfying the criteria for resistance grounded systems, a resistor between the primary neutral and ground can be installed as shown in part (a) of Figure 5-27.

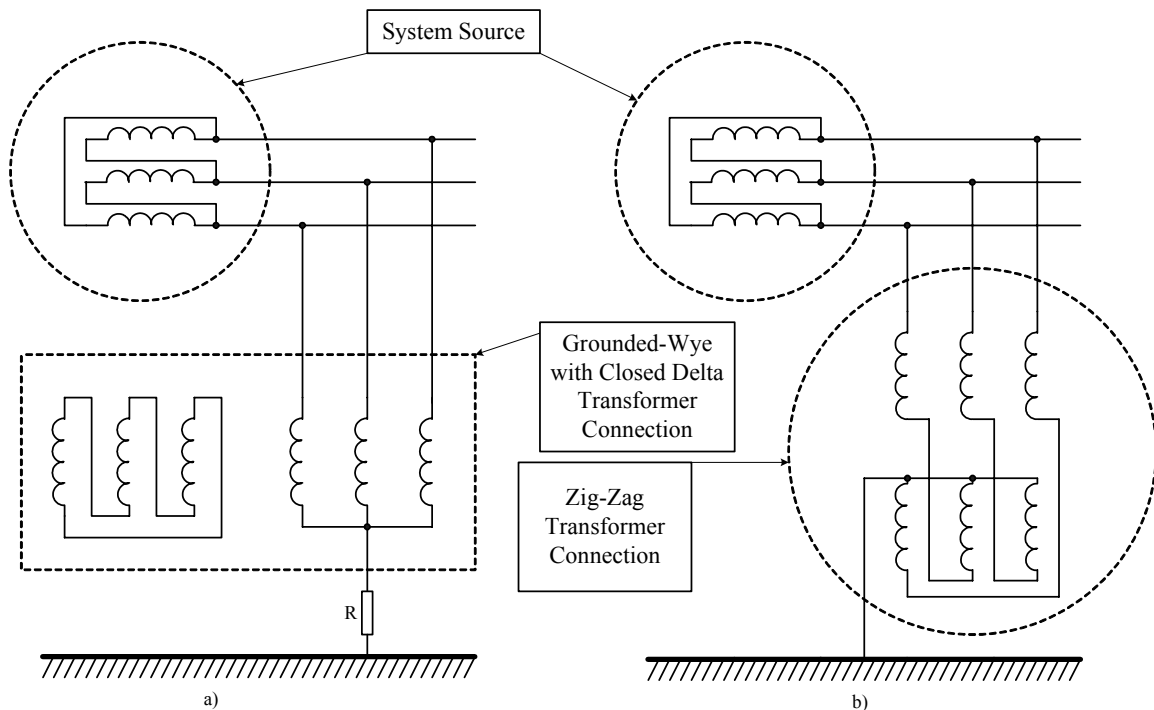

Figure 5-27—Grounding transformers

## 5.2 Lines

When coordinating the overcurrent protection of the distribution system, the conductor damage curve should be considered. Conductor damage curves are available in reference books from the major manufacturers of the wire. Overhead conductors can be damaged by annealing, a reaction due to heating that significantly reduces the mechanical strength of the metal, or they can sag beyond safety tolerances or they can melt like a fuse element. Annealed conductors will typically remain in service, but over time the weakened metal can fail due to additional stress from wind and weather. While annealing is not as significant of an issue with steel reinforced conductors, if the core becomes deteriorated, then annealing can be an issue. Insulated power cables are also of concern as overheating can result in damage to the dielectric, sheath, extruded jacket, splices, and PVC conduit systems. Since cable systems are direct buried or enclosed in conduit systems, heat dissipation from fault currents takes much longer than for overhead bare

conductors. Coordination with the conductor damage or  $I^2t$  curve is necessary for those systems that have high available fault currents due to low system equivalent impedances and substation transformers with large megavolt-ampere ratings. This can particularly be an issue for systems where the distribution circuits are aging while the substation and sources are being upgraded, resulting in a much higher fault current than that available when the circuits were designed. Parameters to consider in the evaluation are the available fault current, relay time-current curve, conductor  $I^2t$  curve, and effects of reclosing (fast reclose cycles will not allow significant cooling of the conductor between shots). Conductor damage curves are dependent on the characteristics of the conductor and are available in reference books from the conductor manufacturers.

### 5.3 Transformer—Distribution substation

Distribution line protection should consider the transformer damage curves of the substation supply transformer. The transformer damage curves are based on  $I^2t$  of the windings and on mechanical bracing of the windings for through faults. For substations that incorporate a low side transformer breaker, the overcurrent protection associated with that breaker needs to be set more sensitive and faster than the time-CT damage curve. The feeder breaker overcurrent protection time-current curves should then be set more sensitive and faster than the low side transformer breaker protection for a fault on the feeder circuit. For substations that do not incorporate a low side transformer breaker, the feeder breaker overcurrent protection time-current curves should be set below the substation through fault damage curve and should coordinate with the transformer high side protection, keeping in mind that the high and low side current ratio is a function of the type of fault and the transformer connection as illustrated in Figure 7 of IEEE Std C37.91™-2000 [B44].

Primary fuses on distribution transformers, when used, should protect the transformer in the same manner as previously mentioned. It is often advantageous to only consider the coordination with the largest distribution transformer for each coordination path as all smaller transformers will then coordinate with the upstream feeder protection.

#### 5.3.1 Winding configuration

In general, the common practice in North America is to operate three phase distribution systems in a four-wire grounded-wye mode. This practice dictates that the transformer LV or secondary winding is connected in wye and solidly grounded at the common wye connection. It is also common practice that the primary HV winding be connected in delta. This provides advantages for the application of protective relays on the primary supply system.

Transformer banks with a capacity greater than 3000 kVA are generally three-phase units. Smaller banks are often comprised of three single-phase transformers. Figure 5-28 illustrates these differences.

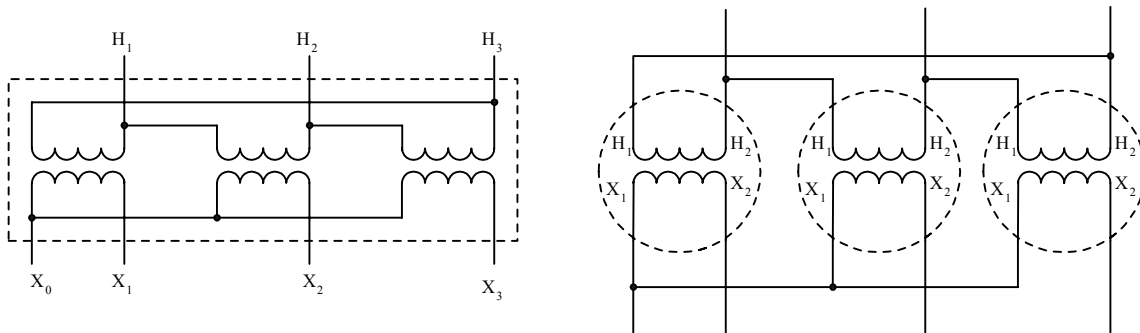

Figure 5-28—Three-phase and single-phase transformer connections

### 5.3.2 Impedance

Preferred standard values of transformer impedance are provided in Table 10 of ANSI C57.12.10-1997 [B3], which is shown as Table 5-2. IEC 60076-5:2006 [B28] Table 1, specifies minimum values of impedance for two winding transformers. Variation from these values may be required in some applications to limit distribution bus fault magnitudes.

**Table 5-2—BILs and percent impedance voltages at self-cooled (OA) rating**

High-voltage BIL (kV)	Without load tap changing		With load tap changing
	Low voltage 480 V	Low voltage 2400 V and above	Low voltage 2400 V and above
60–110	5.75 <sup>a</sup>	5.5 <sup>a</sup>	—
150	6.75	6.5	7.0
200	7.25	7.0	7.5
250	7.75	7.5	8.0
350	—	8.0	8.5
450	—	8.5	9.0
550	—	9.0	9.5
650	—	9.5	10.0
750	—	10.0	10.5

<sup>a</sup> For transformers greater than 5000 kVA self-cooled, these values shall be the same as those shown for 150 kV HV BIL.

Source: ANSI C57.12.10-1997 [B3].

## 5.4 Protective devices

### 5.4.1 Relay

Relays are devices that respond to signals from sensors (voltage, current, temperature, etc.), and operate contacts based upon predetermined criteria. These contacts are usually wired to the trip coil of a circuit breaker or a lockout relay. A relay can also be used as a control device to operate a circuit breaker after a preset time interval.

Next to a fuse, the overcurrent relay is the oldest, least expensive and simplest form of fault detecting device. The initial designs were single-phase electromechanical relays that measured phase and ground current to provide phase and ground fault protection. Three-phase overcurrent relays were developed that derived sequence currents for use in detecting phase and ground faults. Relays with instantaneous or numerous time delay characteristic shapes are available. Where the systems are not radial, a directional element using a polarizing voltage and/or current for reference is added to supervise the overcurrent element.

While the simple single- and multi-phase overcurrent devices are still applied, the microprocessor-based numerical relays with numerous functions are becoming more common. In these relays, the “overcurrent relay” is often just one of many functions included, and it may use any combination of sequence currents to produce its operating characteristics.

## 5.4.2 Recloser

A recloser is a protective device that combines the sensing, relaying, fault-interrupting, and reclosing functions in one integrated unit. Reclosers can be placed in substations or out on the distribution lines. The purpose of the recloser is to sense a fault, clear the fault, and attempt to restore service. If the fault is permanent, the recloser should follow a predetermined sequence of open and close operations before locking out in the open position.

Reclosers may be classified in a number of ways: by their interrupting medium, by their means of control, and by their number of phases.

### 5.4.2.1 Interrupting medium

At present, reclosers use either oil or vacuum for their interrupting medium. Historically, oil has been used. In the late 1960s, vacuum was introduced, and is now the predominate interrupting medium being used. The high-voltage dielectric insulating medium for vacuum reclosers can be oil, air, or a solid dielectric.

### 5.4.2.2 Control

Recloser characteristics, such as timing, counting, and reclosing, can be controlled by either a hydraulic or an electronic method.

Hydraulic control is associated with series trip coil reclosers. In all hydraulically controlled reclosers, overcurrents are sensed by a series solenoid. Since the viscosity of the hydraulic fluid varies over temperature, the timing has been known to increase as the temperature decreases.

Electronic control is associated with shunt trip coil reclosers. It uses a separately mounted electronic control, or set of overcurrent and reclosing relays to provide trip timing, counting, and reclose interval timing characteristics. These controls are more accurate, repeatable, and flexible than the hydraulic control.

### 5.4.2.3 Number of phases

Reclosers are designed as three-phase and single-phase devices. The three-phase type may operate in one of several modes: single-phase trip, single-phase lockout, single-phase trip three-phase lockout, or three-phase trip three-phase lockout.

## 5.4.3 Fuses

Fuses are the most basic type of devices used for overcurrent protection. There are two fundamental types of fuses in distribution systems: expulsion and current limiting fuses. Before the system is faulted, fuses act as part of the line. However, when the line is faulted, the element, carrying more current than it can handle, heats to its melting point, then breaks apart in different ways depending on the fuse type and the fault current characteristic. Expulsion fuses use gas generation and exhaust to remove conducting particles from the arc column and allow the fuse to interrupt current at current zero. Because expulsion fuses interrupt currents at the current zero, they will let-through up to a full half-cycle of the full fault current before the current interruption and will not limit the fault current magnitude. Current limiting fuses reduce the magnitude and duration of the fault current by introducing a high resistance into the circuit. This action significantly reduces the let-through  $I^2t$  value compared to the  $I^2t$  value of expulsion fuses. The lower  $I^2t$  reduces stress on the power equipment subjected to this fault current.

Current limiting fuses come in three types: backup, general purpose, and full range. Backup fuses are designed for high fault current interruptions but are limited to how low of a fault current that they can successfully interrupt and therefore rely on other devices for low current interruption. General-purpose fuses can interrupt currents that cause the fuse to operate in 1 h or less. Full-range fuses are designed to interrupt any current that causes element melting under normal fusing operations.

#### 5.4.4 Sectionalizers

Sectionalizers are not protective devices, but may be used in conjunction with overcurrent devices. A sectionalizer may be set to open when there is no voltage, after sensing fault current one or more times. This provides an additional place to sectionalize the system, with a device that does not have to interrupt fault current. Application of sectionalizers is beyond the scope of this guide.

#### 5.4.5 Other

In addition to the protective devices described in 5.4.1 through 5.4.4, certain types of pad-mounted overcurrent protective devices can be applied to power distribution systems. These devices are typically self-contained, with the fault sensing and current interrupting components enclosed within the switchgear itself. Time overcurrent, instantaneous overcurrent, phase, and ground sensing are typically included, and settings can be applied via a programmable control or by setting of discrete components such as dip switches. Interruption is typically accomplished via vacuum interruptors.

### 5.5 Switching

During switching, system configuration can have a significant impact on application of protective devices. Feeder tie switches are commonly used to isolate sections of the feeder from the normal source and tie it to an adjacent feeder. This facilitates maintenance and outage restoration and allows feeder loads to be balanced by switching loads between feeders.

If the tie switch consists of a set of three single-phase switches, each phase is opened individually with a hot stick. It may take several seconds to open all three phases. During this switching time, unbalanced currents will flow. The sensitivity of residual time overcurrent relays may be limited to prevent operation during this switching period. If the tie switches are gang-operated, this is not a limitation.

With single-phase tie switches, it is possible to close one phase of a tie switch for an extended time. This condition may not be advisable because it would cause unbalanced current that could limit sensitivity of residual time overcurrent relays.

When the tie switches are used to connect a section of the feeder to an adjacent feeder, a long circuit can be created. This may result in lower short circuit currents due to the impedance of the longer line and higher load currents due to addition of the switched feeder section to the normal feeder load. This makes lower current pickup settings desirable to detect short circuits, but makes higher current pickups necessary to prevent operation on load current.

### 5.6 Instrument transformers (sensing)

#### 5.6.1 CT/VT

Instrument transformers provide scaled signals for use in the protective relay schemes, stepping the power system currents and voltages down to a manageable level, and providing isolation between the relay system and the primary circuits. Instrument transformer performance can be a significant factor in protective relay scheme performance, since they provide the signals upon which the relays base their responses. In numeric relaying systems, the CT and VT signals will also be used for metering functions.

CTs take the power system currents (primary) and step them down to a lower level (secondary) for relaying. The CT ratio defines this scaling factor, and is specified as the ratio of primary to secondary current (e.g., 1200/5). Multi-ratio CTs are designed with multiple secondary taps, providing more flexibility in setting relay response characteristics, optimizing the relay system performance, and allowing standardized hardware. The CT accuracy class is determined by a letter designation and a secondary voltage terminal rating (see IEEE Std C57.13). IEEE Std C37.110™-1996 [B47] provides guidelines to

insure that CTs are applied correctly for protective relay applications. CTs are necessary for all forms of overcurrent relaying (time or instantaneous, phase, neutral, or negative sequence)

VTs step the primary power system voltage down to a lower voltage for the relay (secondary) circuits. As with CTs, VTs are specified based on their turns ratio. VTs are necessary for voltage-based relaying, including overvoltage and undervoltage and overfrequency and underfrequency. VTs can also provide polarizing signals for directional overcurrent schemes.

### 5.6.2 Location and configuration (wye/delta)

In distribution applications, CTs are required for each protected feeder as shown in Figure 5-29. The CTs are usually located on the bus side of the feeder circuit breaker, or associated sectionalizing device. This ensures that any fault on the line side of the breaker or the breaker interrupting components will be seen by the connected overcurrent relays (no unprotected area between breaker and CT). CTs are usually connected in wye, with a CT for each phase. This allows direct measurement of the phase and neutral currents. If desirable, the residual (zero sequence) and negative sequence currents can be derived (see Figure 5-30).

VTs are usually connected to the power system bus, since a voltage disruption will be equally distributed within the substation. Line side VTs may be required for permissive closing schemes, if the distribution lines are not radial, or if DRs are present on the lines. VT primaries can be connected wye or delta, depending on needs. Three wye-connected VTs provide three phase-to-phase and phase-to-neutral voltages [see part (a) of Figure 5-31]. The open delta VT connection provides three phase-to-phase voltage measurements using only two VTs [see part (b) of Figure 5-31]. The VT connection must be appropriate for the application and relays selected. A more detailed discussion of voltages available from VTs is included in 6.3. VTs are usually connected with primary fuses to isolate failed VTs from the power system.

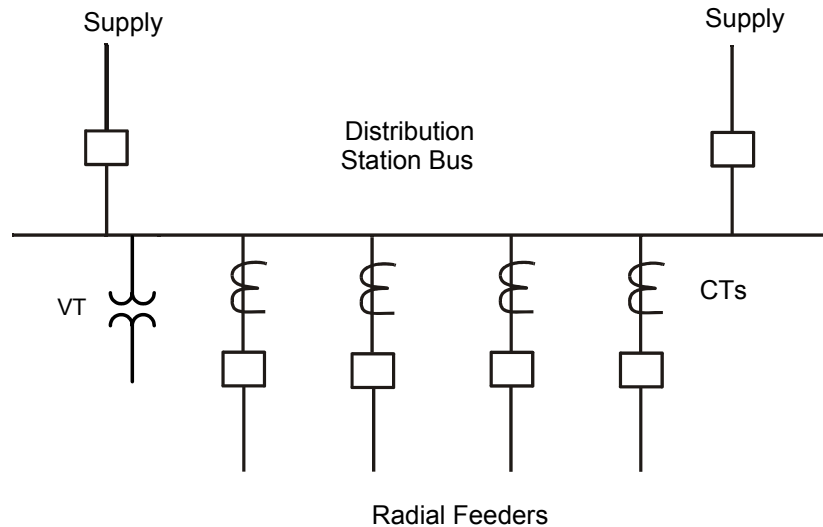

Figure 5-29—CT and VT location in a distribution station

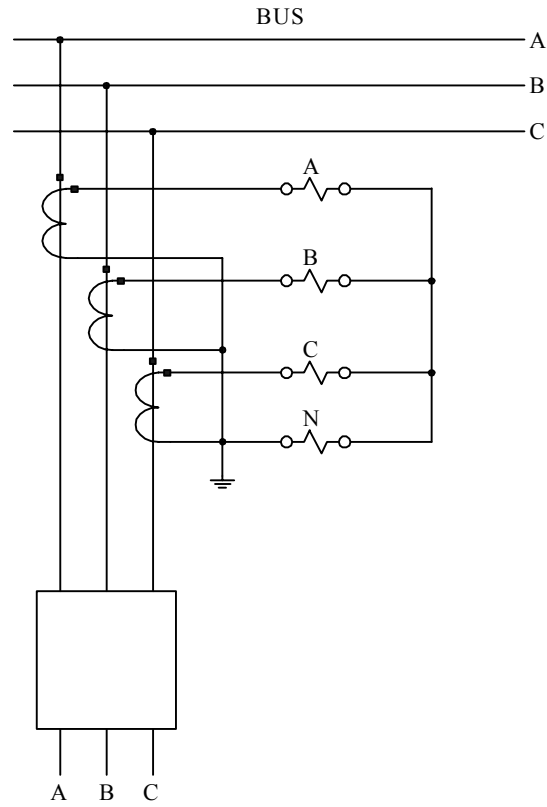

Figure 5-30—CT connection, 3-wire

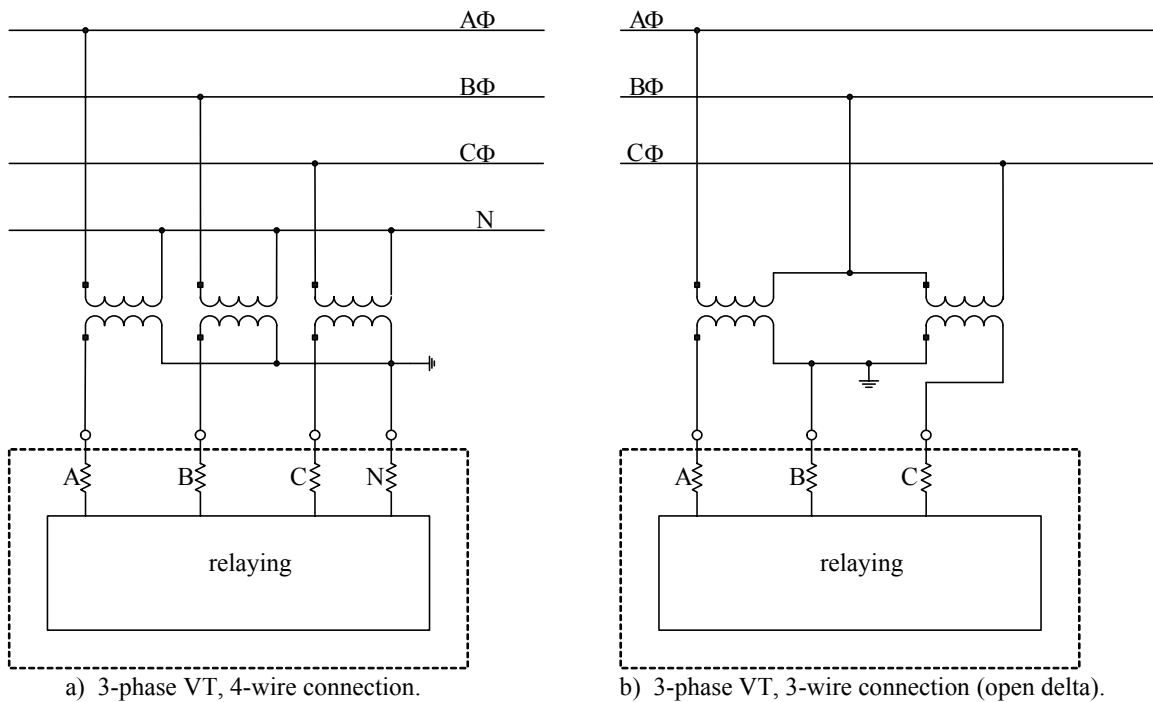

Figure 5-31—VT connections

### 5.6.3 Accuracy and ratings

Relaying CTs should operate reliably over a wide dynamic range, from current levels well below rated current, to many multiples of rated current. Relay class CTs are rated for either 5 A or 1 A nominal secondary current, and are specified to have less than 10% error with up to 20 times rated current while feeding up to a standard burden. For instance, a 5 A secondary rated C100 accuracy class CT is defined to have less than 10% error over a range of up to 100 A (20 times rated) through a burden of up to 1  $\Omega$ , without saturating (see IEEE Std C37.110-1996 [B47]).

VTs are not required to operate over as wide a dynamic range as CTs, since the voltage collapses during faults. Maximum voltages expected should not exceed 3.0 pu (for ferroresonance), with normal voltages within a close band of nominal. VTs are usually rated 69 V or 120 V phase-to-neutral across the secondary windings. The 69 V tap provides 120 V phase-to-phase voltage.

### 5.6.4 CT saturation

CT saturation causes distortion in the secondary current waveform and a decrease in CT accuracy. This can be due to abnormally high primary currents, excessive connected burden, or remnant flux. These conditions can create high flux density in the CT's iron core, leading to excessive excitation current,  $I_e$ . This results in a secondary current less than would be indicated by an ideal CT. With reference to the CT equivalent circuit shown in Figure 5-32, as  $I_e$  gets large,  $I_s$  does not replicate  $I_p$  well.

The CT excitation current is indicated by the V-I characteristic curves, as shown in Figure 5-33. Excitation current is generally low, compared to secondary current, unless the secondary excitation voltage  $V_e$  exceeds the knee-point of the curve. At this point, a small increase in excitation voltage results in a very large increase in excitation current.

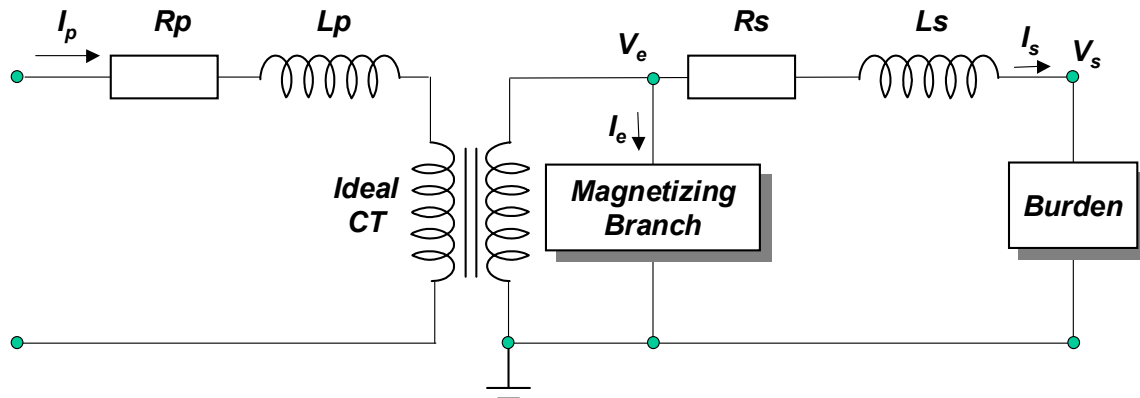
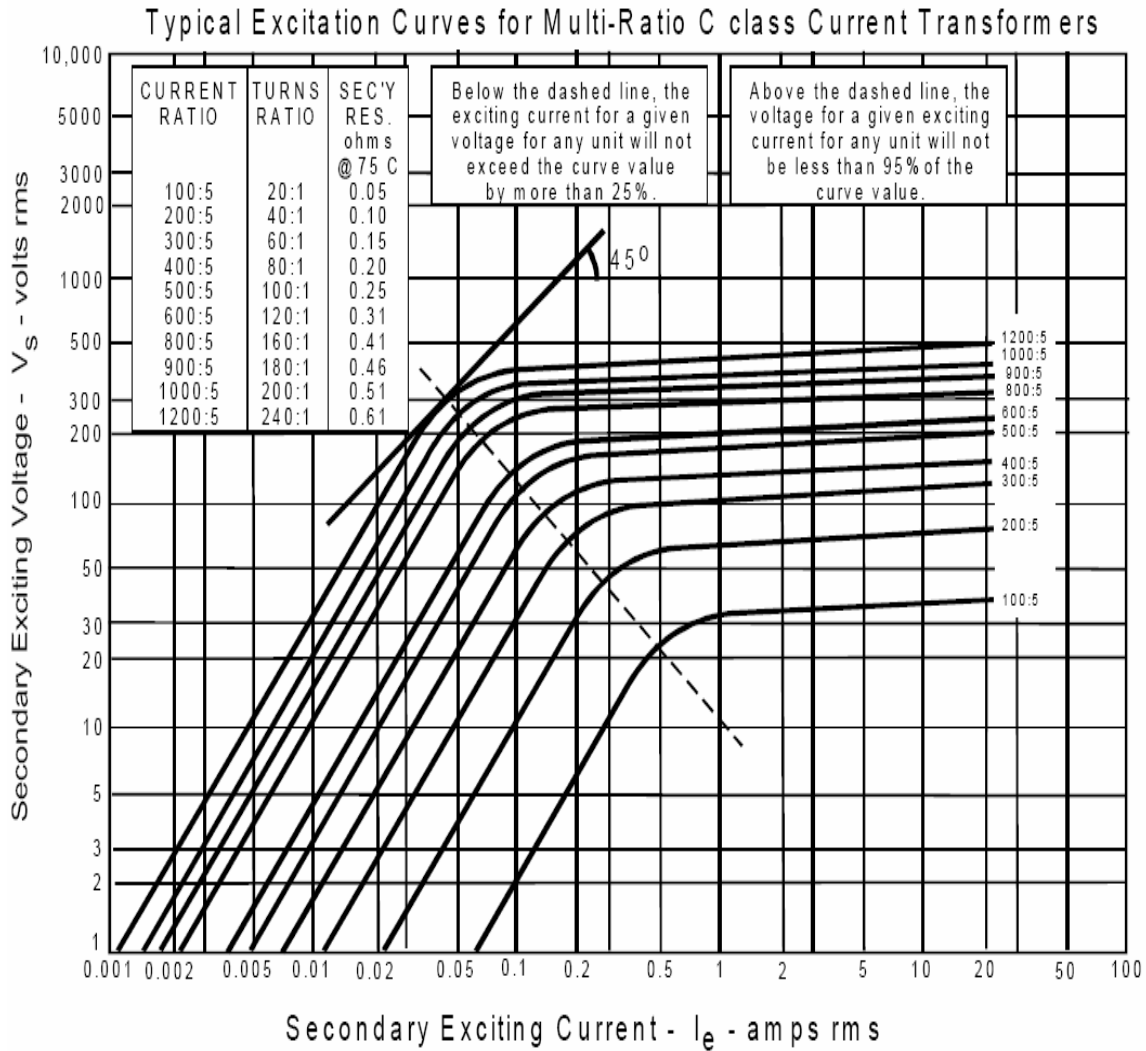

Figure 5-32—CT equivalent circuit



**Figure 5-33—Typical excitation curves for a multi-ratio C class CT**

CT saturation (see Figure 5-34) can decrease the current through the relays and cause under-reaching of the protection scheme. To limit the possibility of saturation, the burden connected to the CTs should be kept as low as possible. This will decrease the required secondary excitation voltage ( $V_e$  in Figure 5-32) and associated excitation current  $I_e$ . Figure 5-34 shows a 1200/5 A, C400 CT performances for two different fault currents and burden. The CT slightly saturates at 20 times CT rated current ( $20I_N$ ) but is within the 10% accuracy error as defined by the IEEE Std C57.13. At  $40I_N$ , the CT heavily saturates with rated burden of 4  $\Omega$ . The CT saturation is significantly smaller with reduced burden to 2  $\Omega$ , demonstrating the burden impact on the CT saturation.

CT saturation can also be caused by the dc component of an asymmetrical fault current. The effect of dc component on the CT saturation is shown in Figure 5-35. After saturation occurs, the decay of the dc component will allow the CT to recover. In three-phase systems, the offset will be different on each of the phase CTs, causing different CT saturation in each phase as shown in Figure 5-36. This will result in residual current  $I_R$  and can cause false signals in residually connected protective devices.

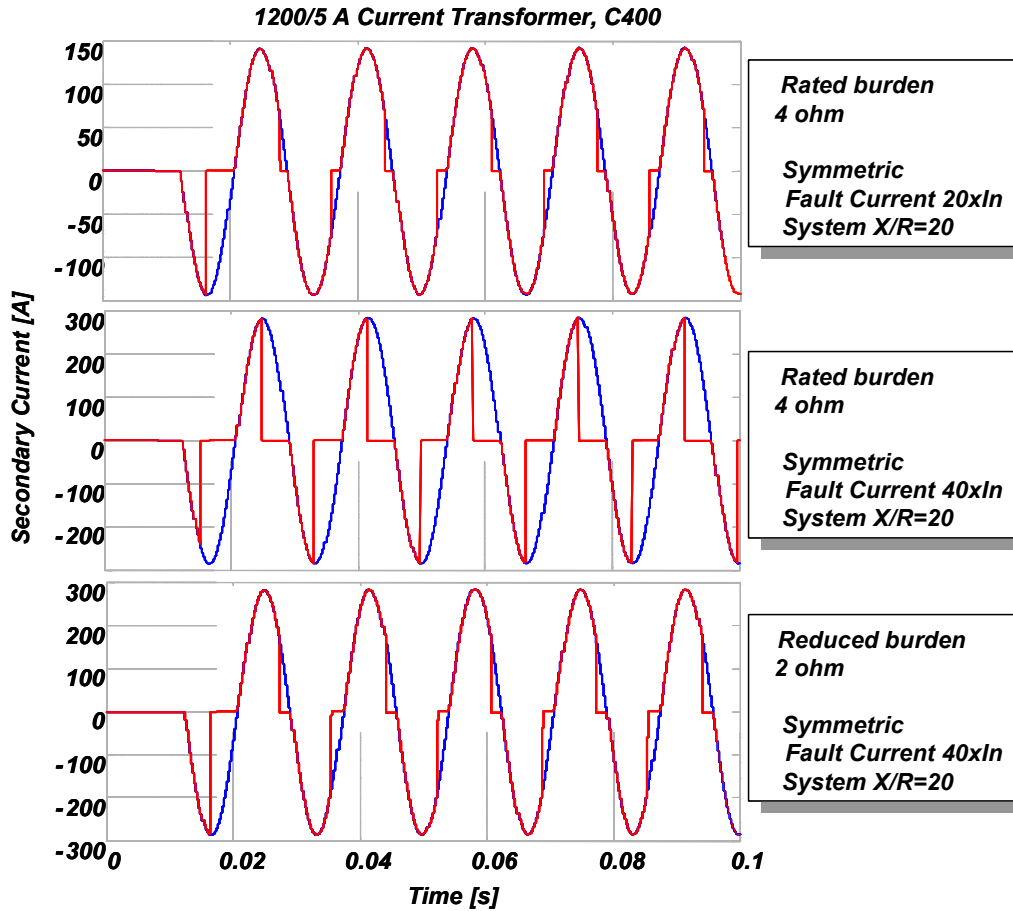

Figure 5-34—CT saturation at rated burden and reduced burden

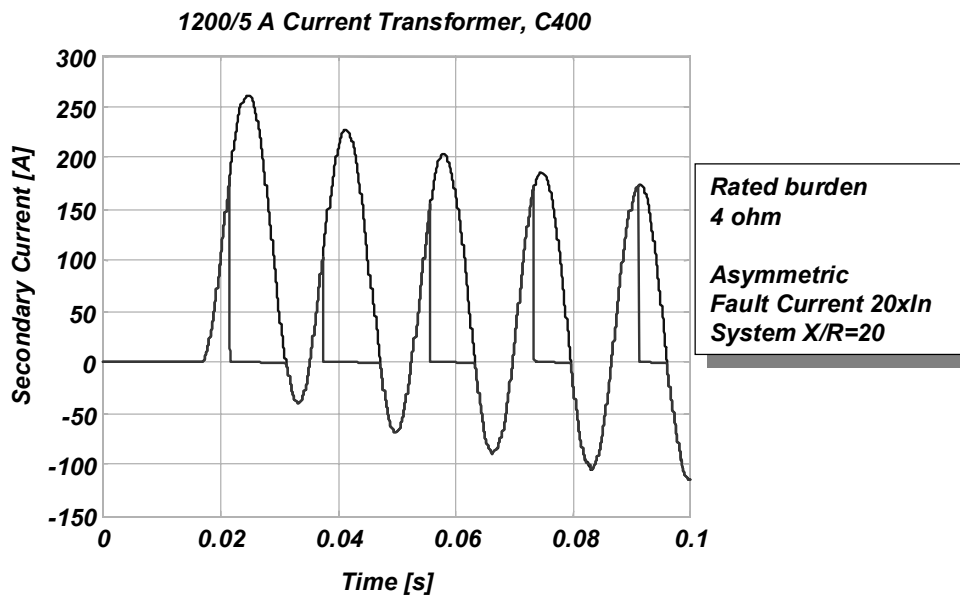

Figure 5-35—Effect of dc component on CT saturation

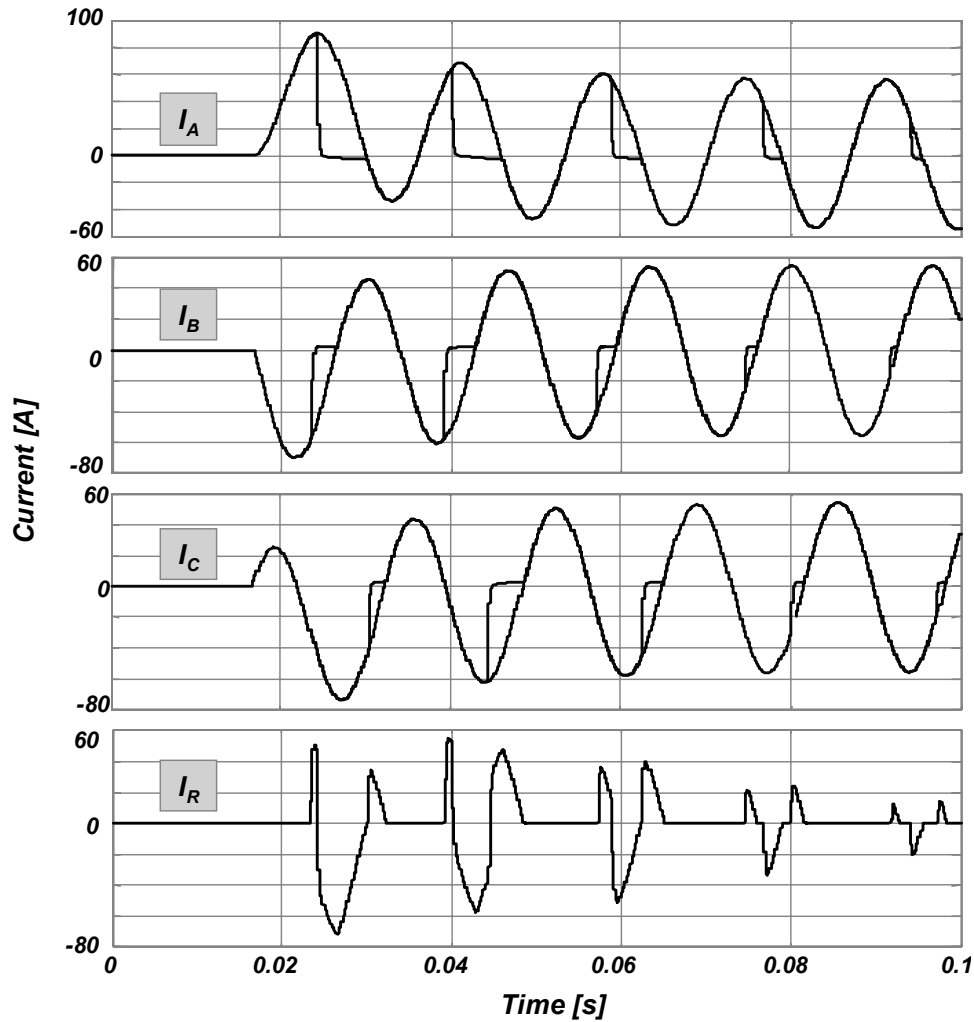
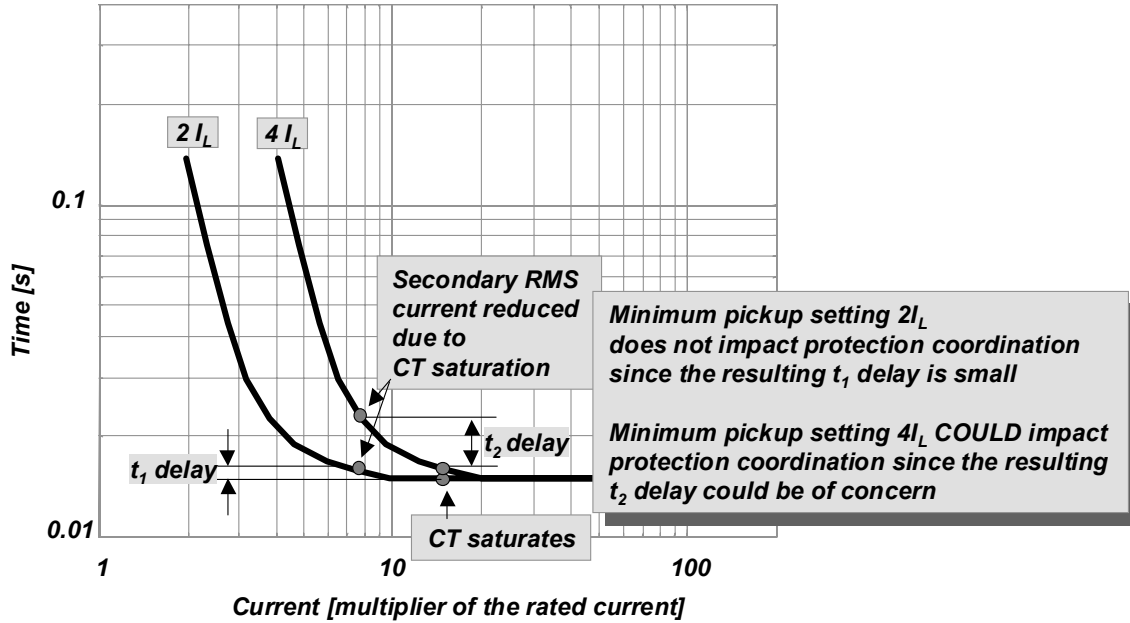

Figure 5-36—Residual current caused by CT saturation due to dc components

CT saturation will not always impact relay coordination. This depends on the time-current characteristic (TCC) curve used, protection setting, and the fault current relative to CT saturation points. In practice, the load current  $I_L$  has been used to determine the minimum pickup for phase and ground (residual) time overcurrent elements for relays and reclosers. Normally, when calculating the phase minimum pickup/trip, a factor of 1.5 to 3.0 times normal load current  $I_L$  is included to account for load growth, contingency operating conditions, and cold-load inrush currents. With this setting philosophy, CT saturation should not be a factor that causes overcurrent protection misoperation when using fast TCC curves. Figure 5-37 shows that at minimum pickup setting of  $2I_L$ , the CT saturation will not impact protection coordination. However, minimum pickup setting of  $4I_L$  could impact protection coordination.



## 6. Protective schemes

### 6.1 Overcurrent scheme

Overcurrent protection is the simplest scheme used to protect transmission and distribution lines. There are three types of overcurrent relays applied on distribution systems:

- a) Phase overcurrent
- b) Ground overcurrent
- c) Negative sequence overcurrent

These relays can be directional or non-directional depending on relay type, system configuration, and protection requirements. For radial distribution, non-directional overcurrent relays are applied; while for network or looped systems directional overcurrent relays are more appropriate. This guide does not cover the application of directional overcurrent relays.

In almost all cases, the distribution feeder protection begins at the substation with a feeder breaker or recloser (see 5.4.2). This device should be coordinated upstream with the main bus breaker or transformer high voltage protection depending upon the substation design and with downstream devices. Downstream devices are generally reclosers or fuses. These may be located on the main feeder or tap sections. All of the protective devices placed in series should coordinate on a time-current basis with each other to minimize the impact of an outage due to a fault.

#### 6.1.1 Phase overcurrent relays

Phase overcurrent relays, which respond to line currents, must have minimum response or pickup settings greater than the expected maximum feeder load current. This current may be as high as the maximum load capability of the line.

Other factors to consider when calculating the pickup setting are the cold load characteristics of the feeder and any significant transformer magnetizing inrush current. The magnitude and duration of cold load current varies depending on the type of load and length of outage. Cold load pickup settings are generally required to be greater than pickup settings used for normal feeder loads. Most utilities establish cold load pickup guidelines specific to their own systems. Typically magnetizing inrush is not severe enough or will decay quickly before the feeder overcurrent relay can respond.

To avoid misoperation, the phase overcurrent relay pickup settings are generally 1.5 to 3.0 times the maximum expected feeder load current. The maximum expected feeder load is determined by factors such as cold load pickup, abnormal system configuration, and equipment current ratings.

### **6.1.2 Ground overcurrent relays**

Ground overcurrent relay pickup must be greater than the zero-sequence current unbalance expected on the feeder. Since much distribution load is single phase, it is possible to have substantial residual or zero-sequence current flow in the feeder. Even when phases are well balanced under normal conditions, sectionalizing of a single phase lateral or load transfer to another feeder can significantly affect feeder balance. As a result, most ground relays are set with a pickup range from 25% to 50% of the phase relay pickup, providing some increase in sensitivity for phase-to-ground faults.

Coordination with downstream fuses should be looked at carefully. The fuse must carry maximum phase current and may operate slower than the feeder breaker ground relay for a low-current ground fault. To avoid coordination problems, it is often the practice to set ground relay pickup time-current settings identical to phase relays and give up added sensitivity for ground faults. Another option is to retain the lower pickup and use a relatively long time overcurrent relay setting that allows operation of the downstream fuse before the relay responds.

The majority of faults on distribution lines only involve one phase. The findings of EPRI Project 1209-1 [B19], "Distribution Fault Current Analysis," indicated that 79% of faults on distribution lines only involved one phase. On systems where the majority of the loads are single phase and connected phase-to-neutral, some utilities are implementing single pole tripping at the substation and on pole-mounted fault interrupters. With single pole tripping, only the phase involved in the fault is deenergized. This maintains service to the single-phase customers connected to the other two phases.

### **6.1.3 Negative sequence overcurrent relays**

Similar to ground overcurrent relays negative sequence relays can be set below load current levels and be set more sensitively than phase overcurrent relays for phase-to-phase fault detection. In many applications, phase overcurrent relay pickup settings can be higher allowing more feeder load capability.

Negative sequence relays can also be applied to detect open phase conditions and low side phase-to-ground faults on delta-grounded wye transformers. "Negative-sequence overcurrent element application and coordination in distribution protection" [B18] provides an analysis of the effect of an open phase conductor for both three-wire and four-wire distribution systems. The ability to detect ground faults on the low side of delta-grounded wye transformers allows the feeder relays to source protect numerous tapped delta-wye transformers, saving the cost of local protection if one chooses to do so. Where local protection is installed, the negative sequence relay provides backup at the distribution substation for failure of the local protection.

Negative sequence current caused by feeder load unbalance must be considered when setting negative sequence relays. Transformer magnetizing inrush, cold load pickup, and expected maximum feeder loads are to be considered as well when calculating relay settings.

## 6.2 Fuse saving/blowing schemes

Overcurrent protection schemes for distribution feeders generally fall in two types as follows:

- a) Fuse saving schemes
- b) Fuse blowing schemes

An example system for fuse blowing/fuse saving schemes is given in Figure 6-1.

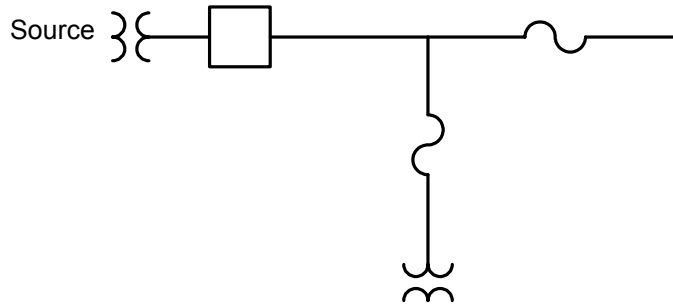

Figure 6-1—Example system for fuse blowing/fuse saving schemes

### 6.2.1 Fuse saving scheme

Distribution fuses require physical replacement after a fault clearing operation. This results in extended outage time to the customer and added expense to replace the fuse. In a fuse-saving scheme, breakers or reclosers are set such that they trip before the fuse operates and then automatically reclose. In many cases, faults are only temporary and the line will successfully reclose, causing only a momentary disruption. This type of scheme is effective on long multi-tapped rural distribution feeders with primarily residential load that is not as sensitive to momentary outages. Fuse saving for this scheme requires that a recloser fast curve as shown in Figure 6-2 (or a “low set instantaneous element” in the case of a station breaker) be set below the minimum melt curves of those fuses that are not to operate on temporary faults. After one or two operations on the “fast” curves, the next trip is set such that the fuse will operate first to clear the persistent fault before the breaker or recloser trips again, as shown by the recloser slow curve in Figure 6-2. This provides one or two opportunities for a temporary fault to be cleared before the fuse is allowed to operate. Permanent faults typically need to be located and physically removed before the line can be put back in service so replacement of the fuse does not seriously extend the outage duration. Application of fuse saving schemes is only applicable to in-line or tap fuses. Care should be taken to consider that transformer fuses are not included in the fuse saving scheme as transformer faults are usually permanent and should be cleared immediately with the transformer fuse to limit further transformer damage or damage to other equipment.

Figure 6-2 is a time-current coordination graph for a fuse saving scheme. The recloser fast curve would cause the recloser or circuit breaker to operate before a fuse. The recloser slow curve is set slower than the fuse curves to allow fuse operation first.

### 6.2.2 Fuse blowing schemes

For distribution feeders where loads are sensitive to momentary outages and significant disruption occurs if the line is momentarily deenergized, a fuse blowing scheme is used to limit the number of main feeder trip-reclose cycles. This scheme is often used on feeders serving industrial plants and urban load centers where a number of trip-reclose cycles could result in equipment damage or added risk of personnel injury. In this type of scheme, the overcurrent relay or recloser control curves are set above fuse curves such that fuses operate first to clear the faulted line section and the substation device serves as a backup in case the fuse fails, in addition to its function of operating for faults on the main feeder trunk.

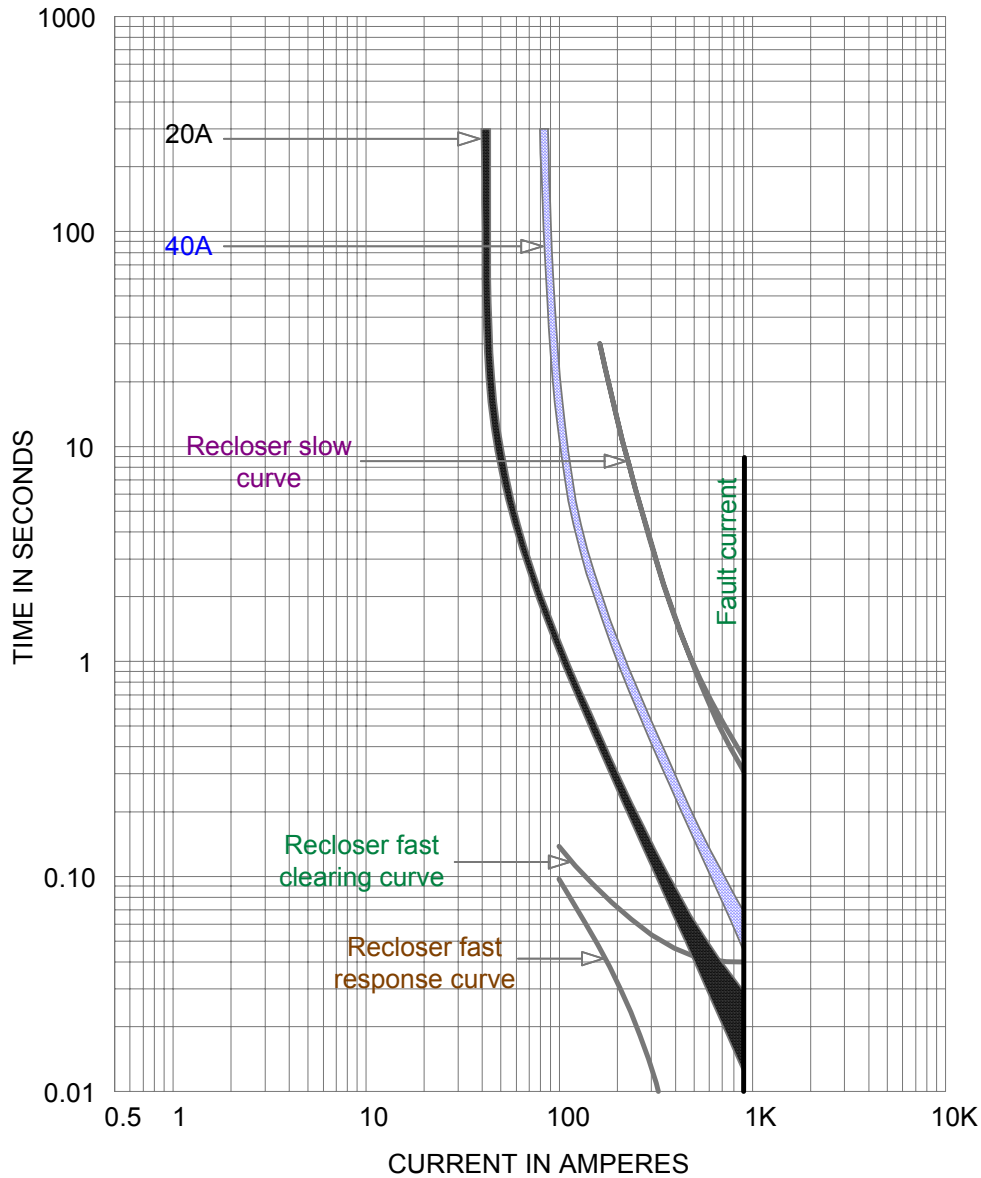

**Figure 6-2—Time-current curve showing fuse saving scheme**

Most underground cable faults are permanent and do not self-clear. Typically, cable insulation has been breached or termination/switching equipment has failed, resulting in a permanent fault. Underground cable should always be protected using a fuse blowing scheme for the riser pole fuses. Compromises may be made on an individual basis for circuits that are primarily overhead with short underground sections connecting significant overhead sections, such as at a road crossing.

Figure 6-3 is a time-current curve for a fuse blowing scheme. Here only a slow recloser curve is used that allows sufficient time for fuse operation to occur prior to response by the main feeder recloser or breaker.

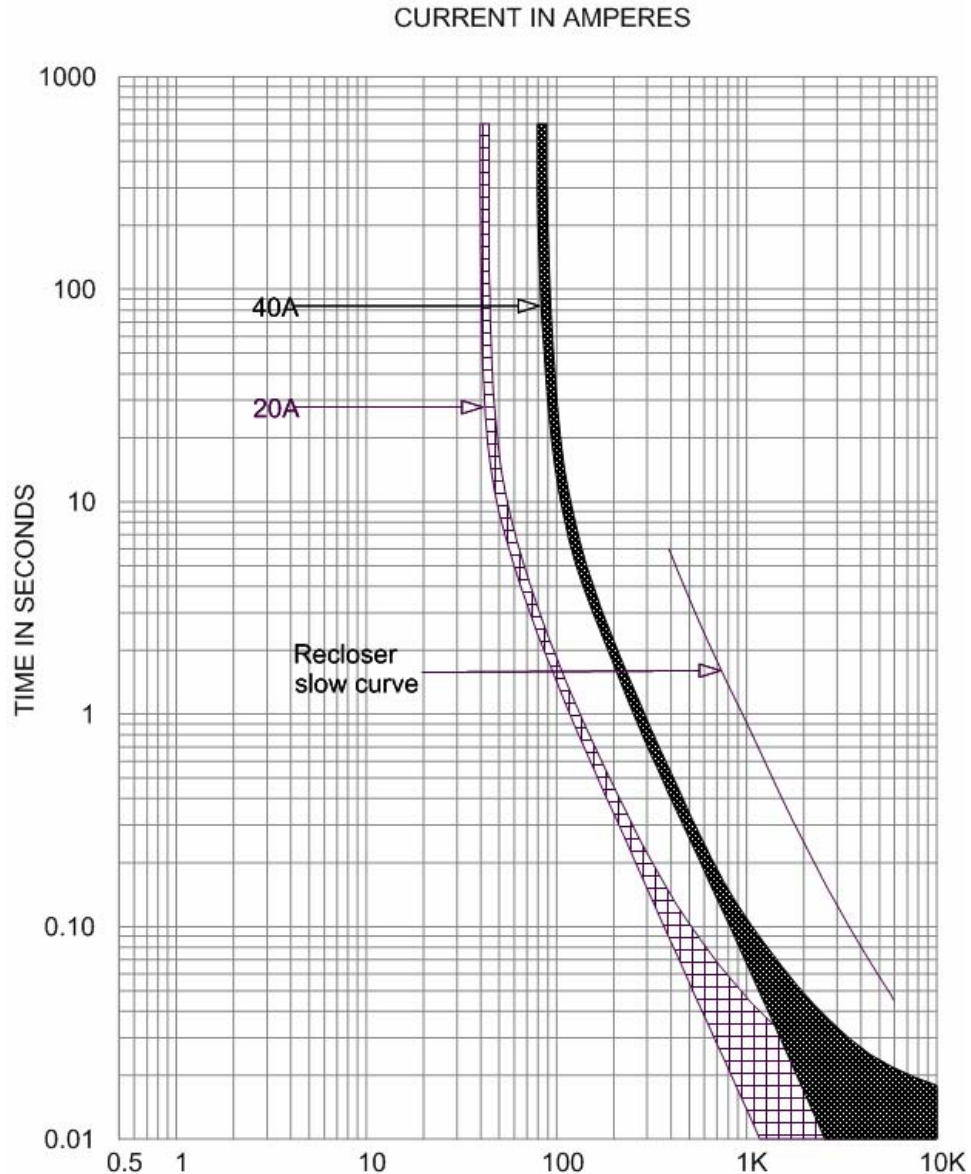

Figure 6-3—Time-current curve showing fuse blowing scheme

### 6.3 Voltage scheme

Voltage sensing relays are used in a wide variety of applications. Some of these applications are: to protect equipment (e.g., power transformers) from damage; to determine if a supply source is healthy or not (i.e., source transfer schemes); to detect ground faults on normally ungrounded systems; to supervise automatic or manual closing of circuit breakers; to determine whether a single breaker pole is open or closed undesirably; to detect unbalanced voltage due to a blown fuse; and to supervise or restrain overcurrent elements for fault detection near generation sources.

The voltage elements can be overvoltage or undervoltage depending on the specific application. Elements are designed to either measure phase-to-phase or phase-to-ground voltage. It is also possible to measure sequence quantities using special transformer connections or with microprocessor relays designed with this feature. As with many overcurrent relays, a time delay is often included as part of the application.

VTs are generally used to step system voltage down to a safer level that is easily measured. Typical low voltage values range between 65 V and 125 V.

### 6.3.1 Overvoltage and undervoltage

Overvoltage elements assert when the measured voltage goes above a predetermined threshold. Conversely, undervoltage elements assert when the measured voltage drops below a predetermined threshold.

### 6.3.2 Phase-to-phase and phase-to-ground

Voltage elements can be connected or programmed to measure either phase-to-phase or phase-to-ground voltage. Phase-to-ground connections (see Figure 6-4) are usually preferred since phase-to-phase quantities can then be calculated. If only one or two VTs are to be used then phase-to-phase connections are generally preferred. It is important to verify that the VTs are rated for phase-to-phase operation (see Figure 6-5). Note that with the phase-to-phase connections shown in Figure 6-5 that zero sequence voltage ( $V_0$ ) cannot be measured. The VT connection should be considered during initial protection system design.

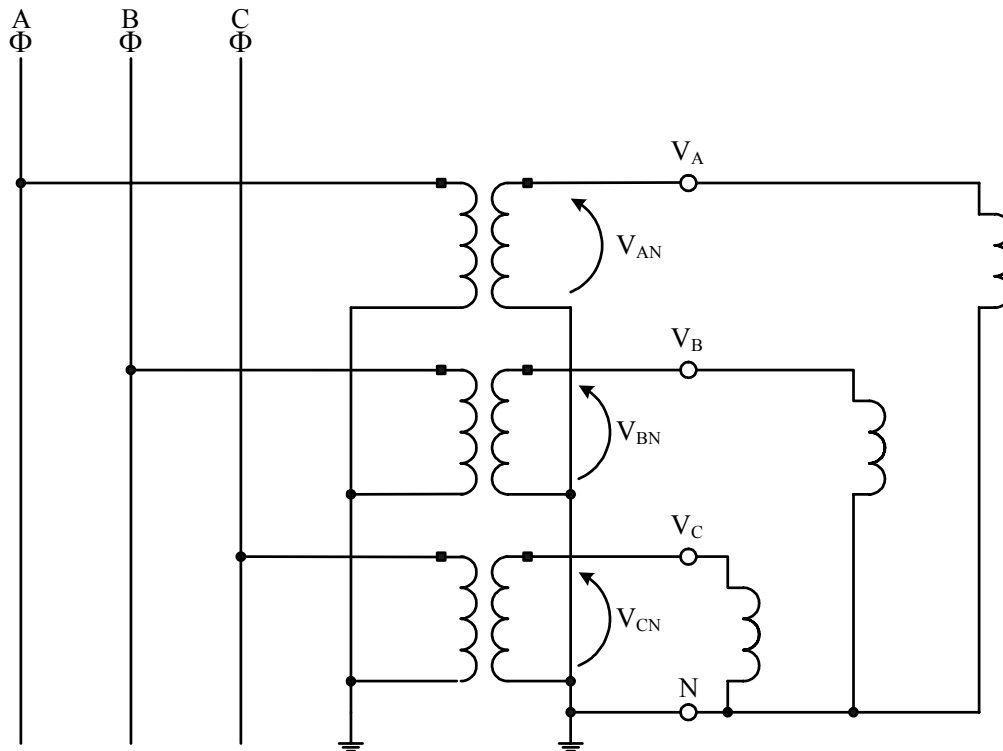

Figure 6-4—Three-phase, four-wire connected VTs

$$V_0 = 1/3 (V_{AN} + V_{BN} + V_{CN})$$

$$V_1 = 1/3 (V_{AN} + aV_{BN} + a^2V_{CN})$$

$$V_2 = 1/3 (V_{AN} + a^2V_{BN} + aV_{CN})$$

where

$$a = 1 \angle 120^\circ$$

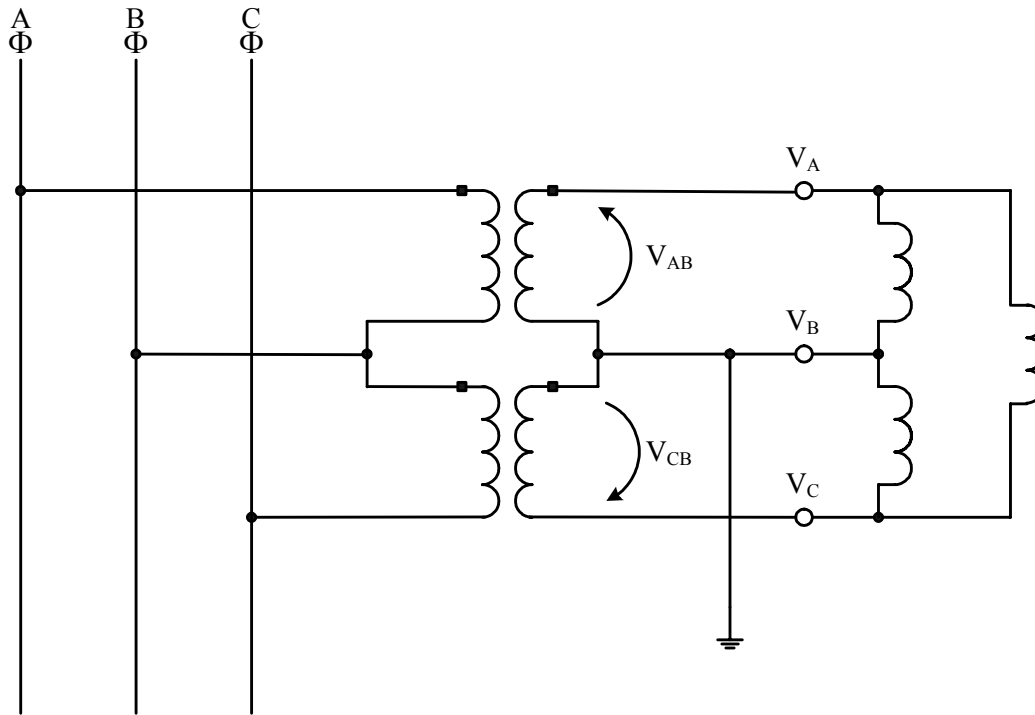

**Figure 6-5—Three-phase, three-wire (open delta) connected VTs**

$$V_1 = 1/3 (V_{AB} + a^2 V_{CB})$$

$$V_2 = 1/3 (V_{AB} + a V_{CB})$$

where

$V_0$  is not available

### 6.3.3 Positive-, negative-, and zero-sequence voltage quantities

Positive-, negative-, and zero-sequence voltage quantities are frequently used for protection and control purposes. Positive-sequence voltage provides three-phase voltage measurement information under balanced system conditions. Negative-sequence voltage has been widely used for detection of a loss of phase, or to detect a blown fuse. Zero-sequence voltage is used for ground fault detection. Zero-sequence voltage can be calculated from three-phase, four-wire connected VTs or measured directly from the wye-broken delta connection shown in Figure 6-6.

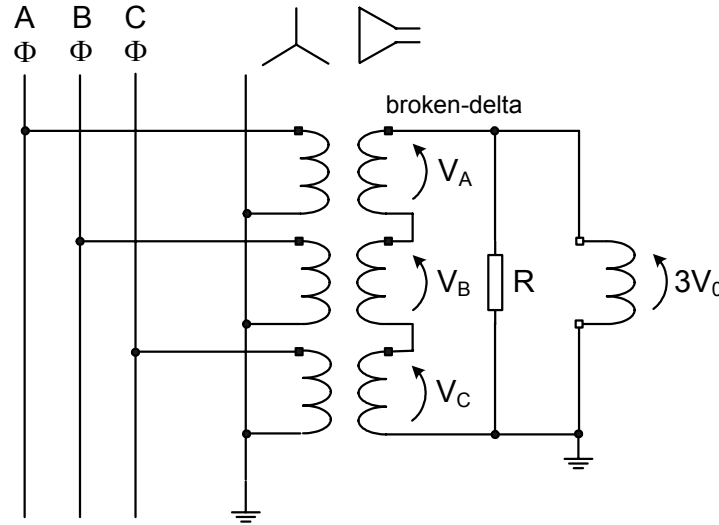

Figure 6-6—Wye-broken delta connected VTs for zero-sequence voltage sensing

$$V_A + V_B + V_C - V_R = 0$$

$$\begin{aligned} V_R &= (V_1 + V_2 + V_0) + (a^2V_1 + aV_2 + V_0) + (aV_1 + a^2V_2 + V_0) \\ &= V_1(1 + a + a^2) + V_2(1 + a + a^2) + V_0(1 + 1 + 1) \\ &= 3V_0 \end{aligned}$$

where

$V_0$  is available

$V_1, V_2$  are not available

## 6.4 Impedance and communications assisted schemes

Impedance protection and communications assisted protection schemes can be applied to distribution systems but are rarely used due to the differences in system configurations, system cost, complexity, and other reasons. Situations that may arise to require these forms of protection are discussed in Clause 8 of this guide. An extensive treatment of these relay systems is included in IEEE Std C37.113™-1999 [B48].

## 7. Criteria and examples

The goal of the utility is to deliver electric energy to the customers in a safe, reliable, and economical manner. Protective relaying is applied to distribution lines to strive and achieve this goal. The goals in applying protective relays to a distribution system are to detect all possible types of fault conditions that could occur, respond to the fault conditions by disconnecting the fault from the source as fast as possible, while affecting the minimum number of customers, and not limiting the capability of the system to carry load current. Since attempting to accomplish some of these goals makes it impossible to accomplish others, compromises are made. The limits of these compromises are the criteria that are used to determine locations for the fault-interrupting devices, and the sensitivity and operating speed of the fault detecting devices.

## 7.1 Reach/sensitivity

### 7.1.1 Phase faults

At least one fault detecting device should be set to operate for phase-to-phase or three-phase faults on the distribution line. Since the source impedance to the origin of the distribution line can vary in most situations, the maximum reasonable source impedance is normally used. Using this maximum source impedance and the impedance of the distribution line, the expected currents for a phase-to-phase fault at the most remote location can be calculated. The phase-to-phase fault current will be 0.87 times the three-phase fault at the same location. A margin can be applied to account for unforeseen operating conditions like arc resistance and fault impedance.

If the relay being used to detect phase-to-phase and three-phase fault conditions is a phase overcurrent relay, its pickup value is set higher than the maximum load current for the feeder. The maximum load current is not just the maximum steady-state load current, it is the maximum cold load pickup current. Following an outage on a feeder, the normal load diversity is lost. The amount of cold load pickup current that is above maximum steady-state load current varies with the load makeup of the feeder. The duration of the cold load pickup will be several minutes, which is well beyond the timing of the phase overcurrent relay so the pickup should be set above this value. A pickup value of 1.5 to 3.0 times the maximum steady-state load current is commonly used.

The conflict between setting the phase overcurrent relays above load current and below the minimum fault current is always present. Since the ability of a system to carry load current is dependent on the same system characteristics as the ability to deliver fault current to a three-phase or phase-to-phase fault, this conflict is normally not a significant problem. However, depending on the configuration of the feeder, some difficulties can exist. A feeder with the majority of the load located close to the substation but with small loads at significant distances away from the substation and small conductor being used to carry the remote loads can create such a scenario. Fault-interrupting devices like fuses or reclosers may need to be installed remote from the substation on the feeds to the remote loads. With these remote devices, the substation relays need only to be able to detect faults as far away as the remote fault-interrupting devices. The installation of those devices also can contribute to improving the quality of service to the majority of the customers on the feeder.

If setting the phase overcurrent relay 1.5 to 3.0 times greater than the maximum steady-state load current cannot be achieved without compromising the desired sensitivity, then distance relays should be considered to replace or supplement the overcurrent relays. The distance relay's sensitivity is based on the ratio of the voltage and the current and the phase angle between the two. This makes it possible for distance relays to distinguish the difference between a fault and a load condition, which both draw the same magnitude of current. The coordination of the distance relay with overcurrent fault-interrupting devices out on the feeder can be accomplished by using the distance relay to enable a time overcurrent relay. The overcurrent relay provides a time/current characteristic similar to a fuse or recloser, and the distance relay makes it possible to set the overcurrent at or below the maximum load current.

Still another alternative in dealing with the conflict of high load currents and low fault currents is to apply negative sequence relays in addition to the phase overcurrent relays. The negative sequence time overcurrent relay can be used to detect the low magnitude phase-to-phase faults. These relays must be set above the maximum unbalanced current (i.e., cold load pickup unbalance or loss of single-phase lateral). The negative sequence relay setting is lower than the phase overcurrent relay setting.

### 7.1.2 Ground faults

Although it is desirable to have at least one fault detecting device operate for any phase-to-ground fault on the distribution line, it is not always possible to accomplish this, because the amount of resistance in the fault can range from zero to infinity. A fault caused by the breakdown of the insulation on a feeder pole that conducts through the line hardware and the pole's ground wire will have very low fault resistance, but a

phase-wire lying on asphalt, pavement, or some other non-conductive material will have very high fault resistance. It is not unusual for the amount of fault resistance to change if a fault is not detected for a period of time.

It is reasonable to detect all zero fault resistance phase-to-ground faults. Depending on the type of distribution system, this is accomplished by different methods. Voltage relays connected to the secondary of phase-to-ground connected potential transformers are used to detect the existence of a ground fault on a delta system; however, they cannot determine which feeder the ground is on. On wye systems the current in the neutral and phase conductors can be monitored. On single point grounded wye systems the earth return for the ground fault current will significantly attenuate the fault current if the fault is any significant distance away from the ground reference. On single point grounded systems with loads connected phase-to-phase or phase-to-insulated neutral, overcurrent relays monitoring the ground fault current can be set rather sensitive. On multi-grounded wye systems, which are most common in North America, a neutral wire is run along with the phase wires and the neutral is connected to ground at multiple locations along the line as well as at the wye neutral reference at the source. With this type of system, the magnitude of the ground fault currents can be greater but load will be connected between phase and neutral. On these systems any unbalance in the loading of the three phases will appear in the neutral. The neutral overcurrent relay must be set to not pickup for the maximum unbalance load current including the unbalanced cold load pickup current. Although care should be taken to balance the loading on the three phases, due to hourly and seasonal variations in the load, there will be unbalance load current.

It is impossible to detect all ground faults and not be subjected to tripping on unbalanced load currents. Therefore, some common methods for designing the ground fault detection system for a feeder are as follows:

- Establish a fault resistance target value. Protection is then applied to detect faults with this value or less of fault resistance. The reported results of EPRI Project 1209-1 [B19] generate questions about using significant fault resistance in the design for ground fault detection. The EPRI Report compared the measured values of system impedance to faults detected by overcurrent protection devices to the calculated values, assuming bolted faults. The comparison resulted in an average fault resistance of roughly 2  $\Omega$ . A target fault resistance above this value should be considered to ensure that the protective device operates for the fault.
- Establish a maximum clearing time for ground faults with zero fault resistance (bolted faults). Since the protective devices used on most distribution lines have an inverse time-type characteristic the operating time for a fault with current near the pickup of the device will be very long. By establishing a maximum time for clearing the most remote bolted fault, coverage is provided for some higher resistance faults.
- Set overcurrent relay pickup to some fraction of the bolted fault current at the end of the protection zone. A typical pickup value is one-third of the bolted fault current for ground faults.

### 7.1.3 Transformer magnetizing inrush

Transformer magnetizing inrush does not present a problem on feeders with smaller sized transformers as the diversity of inrush between the individual transformers typically cancels out rather than adding in magnitude that would result in a trip. It does present a problem when large transformers for commercial or industrial loads are connected and should be considered for the largest transformer. Feeder protective devices are typically three-phase tripping and closing mechanisms. When large transformers attached to a feeder are energized by the closing of a three-pole breaker it, is almost assured that one phase will be closed near a low voltage point that results in a large inrush to that phase of the transformer. Transformer magnetizing inrush can be 8 to 30 times the magnitude of the rated transformer current (see “Protective Relaying Theory and Applications” [B1]). The magnitude of this current is dependent on several factors such as size and location of the transformer bank, residual flux, type of iron used in the transformer core, and the voltage of the closing pole (0 voltage induces maximum inrush). Magnetizing inrush is not a symmetrical phenomenon, and the currents are very different between phases. Transformer inrush contains several harmonics with the second harmonic being the highest in magnitude. The duration of the inrush is

dependent on the system and the transformer size. Inrush current magnitude typically decays rapidly over a period of time and for relay coordination purposes it is general practice to assume that the inrush is 10 times the transformer base rated current for 100 ms. High-efficiency transformers have higher inrush values, and the manufacturer should be consulted for approximate values for use in protective device coordination.

Inrush does not generally present a problem for typical time overcurrent relay and fuse coordination. However, the response of the fast curves of reclosers and instantaneous overcurrent relays are quick enough to be triggered by transformer inrush for both phase and ground. When analyzing feeder coordination, transformer inrush should be considered and plotted as a point on the coordination curves per IEEE Std 242™-2001 (*IEEE Buff Book™*) [B37].

The recloser fast curve response time should be set to a time delay above the transformer inrush point. The instantaneous overcurrent pickup should also be set to a current level greater than this point. Another method to avoid tripping on transformer inrush while maintaining sensitive coordination is to momentarily block the use of the fast curve on closing of the device and only trip on the slow curve after the first trip-reclose cycle. Most modern coordination software allows the inrush point to be added to the coordination curve plots for analysis.

A sample feeder is shown in Figure 7-1 with a 5 MVA transformer connected to a 12.47 kV line with an aggregate distributed load of 2 MVA. The substation recloser control is set to pickup for phase faults above 650 A, which is twice the full load of the feeder. Fast response and clear curves are available in many reclosers, which correspond to the fast curve type 1 shown in Figure 7-2. If we assume that the 5 MVA transformer will have a peak inrush magnitude of 6 times full load or 1389 A, the coordination curve plot indicates that the recloser could trip on transformer inrush if one phase closed under the right conditions. If we assume an inrush factor of 10 to allow for some margin, Figure 7-3 shows the selection of a fast curve type 2 to pickup above the inrush point of 2315 A at 0.1 s. In most cases, a factor of 10 has been sufficient to prevent unwanted tripping on transformer inrush; however, this may not provide adequate margin for high-efficiency transformers.

With the increasing use of numerical relays and recloser controls, the response to magnetizing inrush harmonic current is likely to vary between devices due to filtering and internal processing of the fundamental and harmonic current components. The procedures recommended in this guide will prevent unintended relay operation on transformer inrush regardless of the relay or recloser control design.

$$\text{Load} = \frac{7000 \text{ kVA}}{\sqrt{3} * 12.47 \text{ kV}} = 325 \text{ A}$$

Set R pickup to 2\*full load = 2\*325 A = 650 A.

$$\text{XFMR Inrush 1} = \frac{5000 \text{ kVA}}{\sqrt{3} * 12.47 \text{ kV}} * 6 = 1389 \text{ A}$$

$$\text{XFMR Inrush 2} = \frac{5000 \text{ kVA}}{\sqrt{3} * 12.47 \text{ kV}} * 10 = 2315 \text{ A}$$

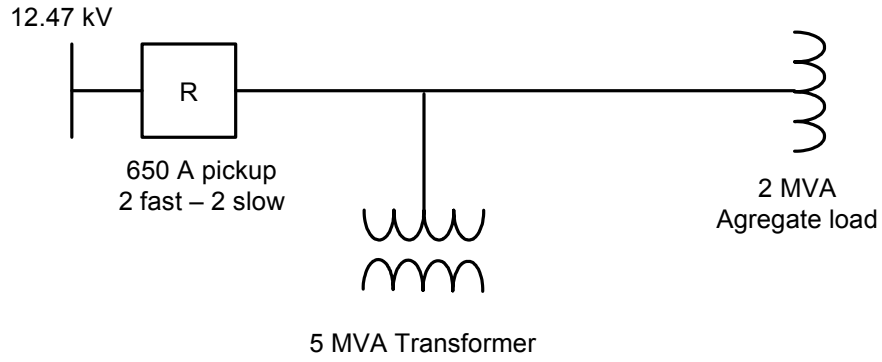

**Figure 7-1—Sample distribution feeder with large transformer**

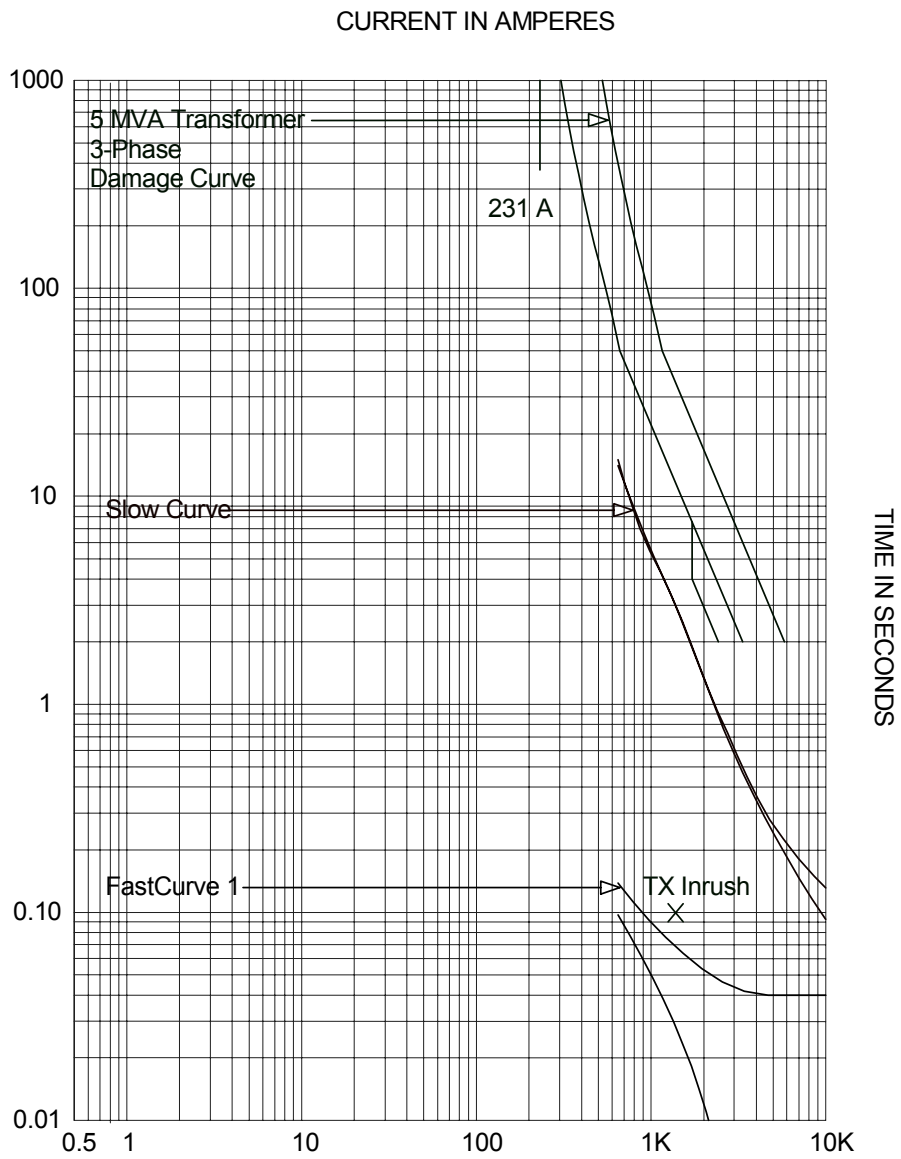

**Figure 7-2—Coordination with large transformer with possible trip on inrush point at 1389 A**

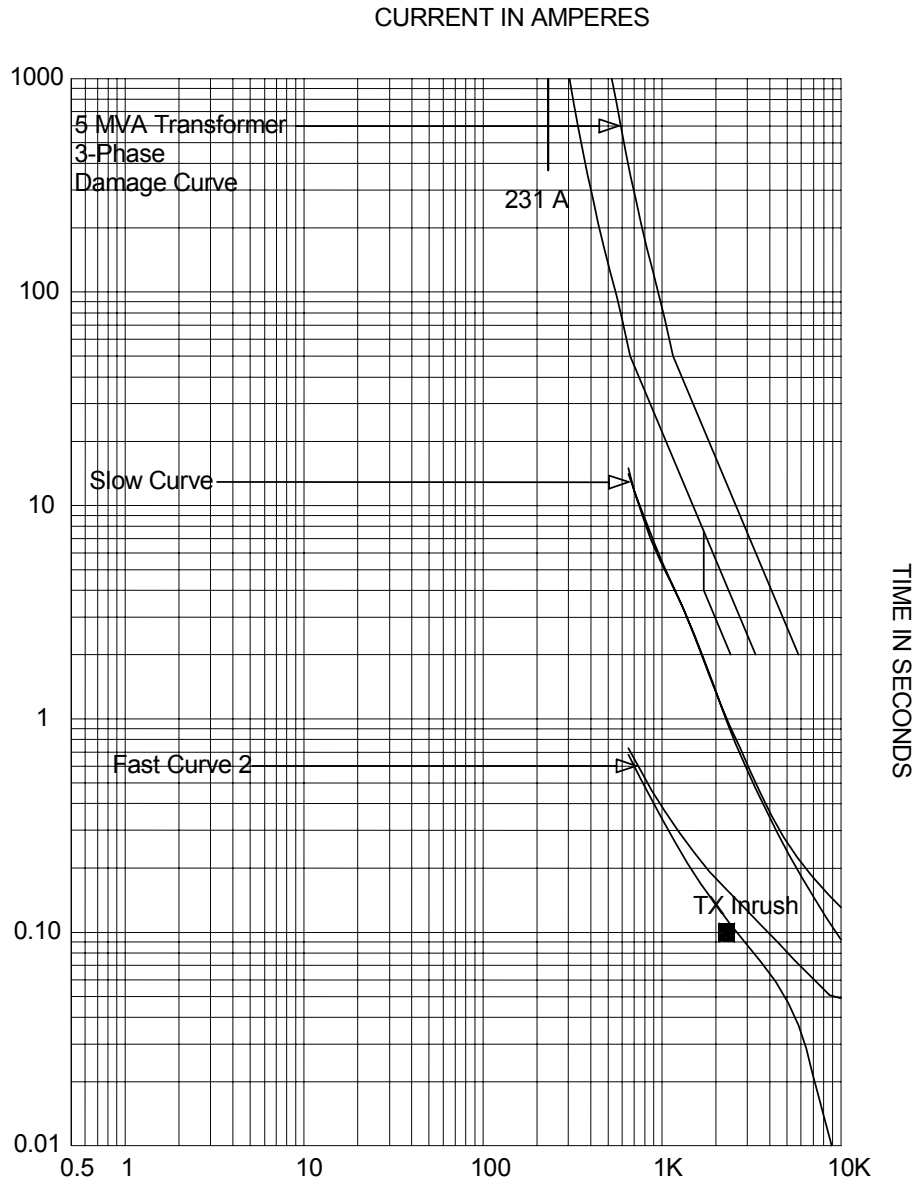

**Figure 7-3—Coordination with large transformer with minimal possibility of trip on inrush point at 2315 A**

## 7.2 Coordination

Being able to detect faults and still being able to carry the load current in many cases cannot be achieved with only protection devices at the substation. Locating fault sensing and interrupting devices out on the distribution line at some distance from the substation will reduce the amount of fault detection coverage that needs to be provided from the substation. Most distribution lines do not have single point loads but have the loads distributed along the length of the line so these remote fault sensing devices will not be required to permit as much load current to flow as the protection back at the substation. The distribution line system most often will not be a single line but a series of line branches that has a structure resembling a tree. Because of this structure, it is typical that the same size conductors will not be used throughout the distribution line system. To protect the smaller conductors on the branches and to minimize the amount of customers disconnected for a fault, fault-interrupting devices can be installed at the branching locations.

To achieve the desired results of sectionalizing the faulted branches of the distribution system while keeping the unfaulted parts energized requires the time coordination of the protective devices, which are operating in series.

While the criteria for sensitivity of the protective devices are based on having one device detecting any fault condition, it is preferable to have two independent devices detecting each fault. By delaying the device closest to the source, the more remote device can time out and clear the fault. In this type of arrangement, the device closer to the source will back up the failure of the remote device.

Most of the devices applied to protect distribution lines have inverse time characteristics. The larger the magnitude of current above the pickup value of the device, the sooner the device will time out and trigger the interruption of the current. This is true for fuses, time overcurrent relays, and reclosers. To time coordinate overcurrent devices, the critical condition to check is normally the response of the two devices for a fault condition that produces the maximum current through the remote device. By comparing the response of both devices for the same fault condition, one can determine if the desired coordination will occur. The remote device should detect and clear the fault before the device nearer the source times out. The two devices may not be monitoring the same magnitude of current if there are multiple sources to the fault or if there are transformers between the devices. In Figure 7-4, both overcurrent relays are sensing the same current.

Figure 7-4 shows the characteristics of both the source and remote overcurrent devices. Both the time coordinate and the current coordinate on the graph are shown using logarithmic scales. The one-line diagram of the distribution line at the bottom of the graph is shown in a scale proportional to the magnitudes of faults along the line. For the fault just beyond device B, device B's response time to the fault current plus the time for device B to interrupt the fault current plus an amount of margin should be less time than the response time for device A. The margin is to cover some unknown conditions and inaccuracies in the: responses of the two devices, CTs, interrupting time of the devices, and modeling.

For a fuse, the response time to trigger the interruption of the current is called the minimum melt characteristic, and the interruption time is called the total clear characteristic.

Three types of devices are typically applied to protect distribution systems: fuses, reclosers, and relays with circuit breakers. All of these devices will interrupt fault current in 0.1 s or less after the response time for the detection of the fault current in the 2 s or less part of their characteristic. For example, maintaining 0.35 s between the response characteristics of each series device will provide for the interrupting time and reasonable margin between the devices.

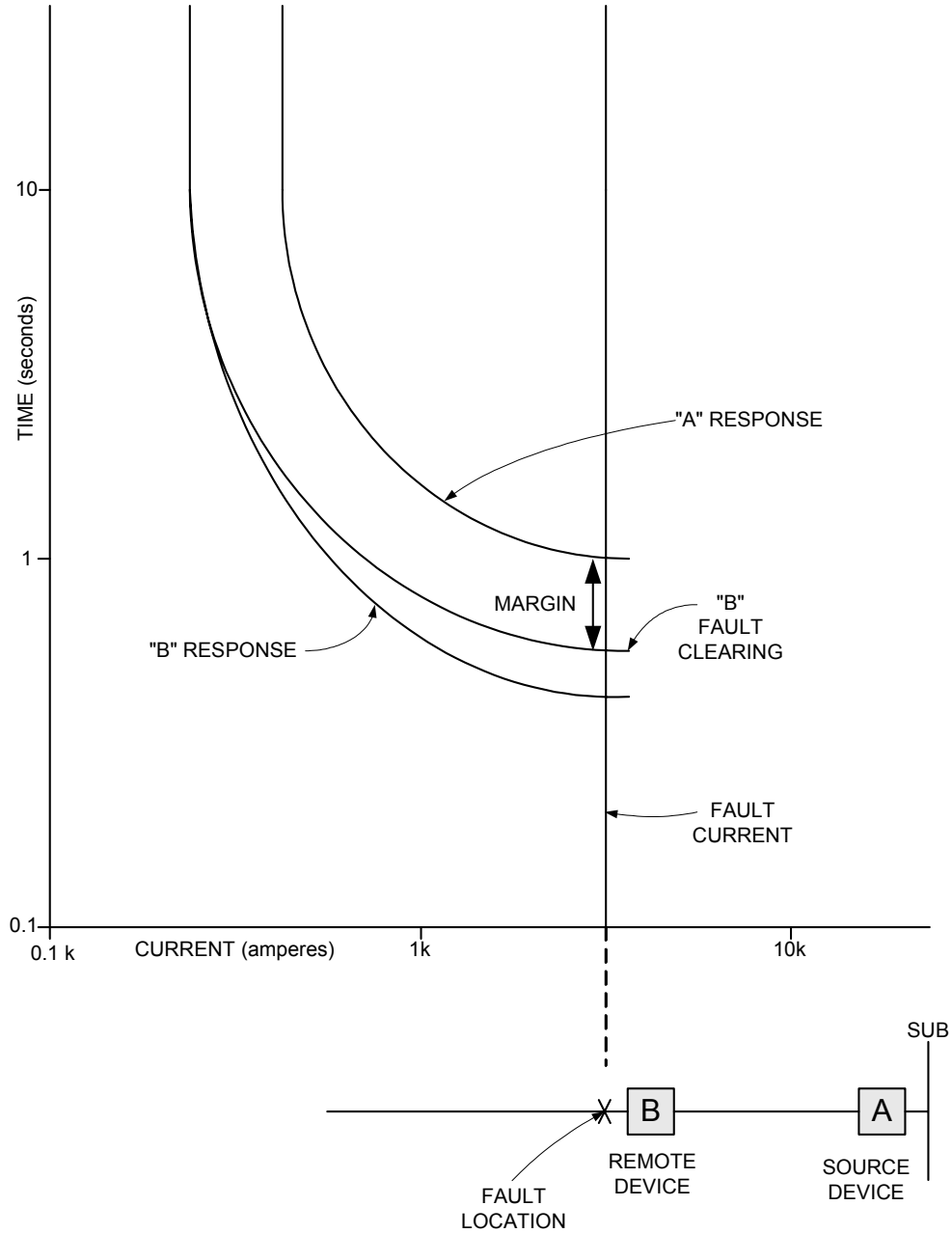

**Figure 7-4—Response characteristic of source and remote overcurrent devices**

Figure 7-5 shows the coordination between three devices. Device C is a line fuse, device B is a line recloser, and device A is a relay with a circuit breaker in the substation. Maintaining 0.35 s between the minimum melt time of the line fuse and the response time of the controls on the recloser for fault location 1 and maintaining 0.35 s between the response time of the recloser and the response time of the relay for fault location 2 establishes the needed coordination for this system.

For long feeders with several protective devices in series with each other, particularly on rural electric systems, the 0.35 s margin between response curves discussed here may not be practical. Such systems may require tighter coordination between devices as discussed in detail in *Electrical Distribution-System Protection* [B12]. However, extra care should be taken to ensure proper coordination between devices

when reducing the time margin between response curves as the timing tolerance for many devices can play a larger role in coordination when using this method.

The shape of device characteristics being coordinated may not be the same as the devices shown in Figure 7-5. If a device with an extremely inverse characteristic is being coordinated with a device with an inverse characteristic, it is likely that the time-current response curves will cross at some current value. This type of coordination is shown on Figure 7-6. The area circled appears to be a miscoordination between the fuse and the recloser. If this area of apparent miscoordination occurs in a period of time that is longer than the target fault clearing time for the feeder protection, then the apparent miscoordination is tolerated. Figure 7-6 shows such a case.

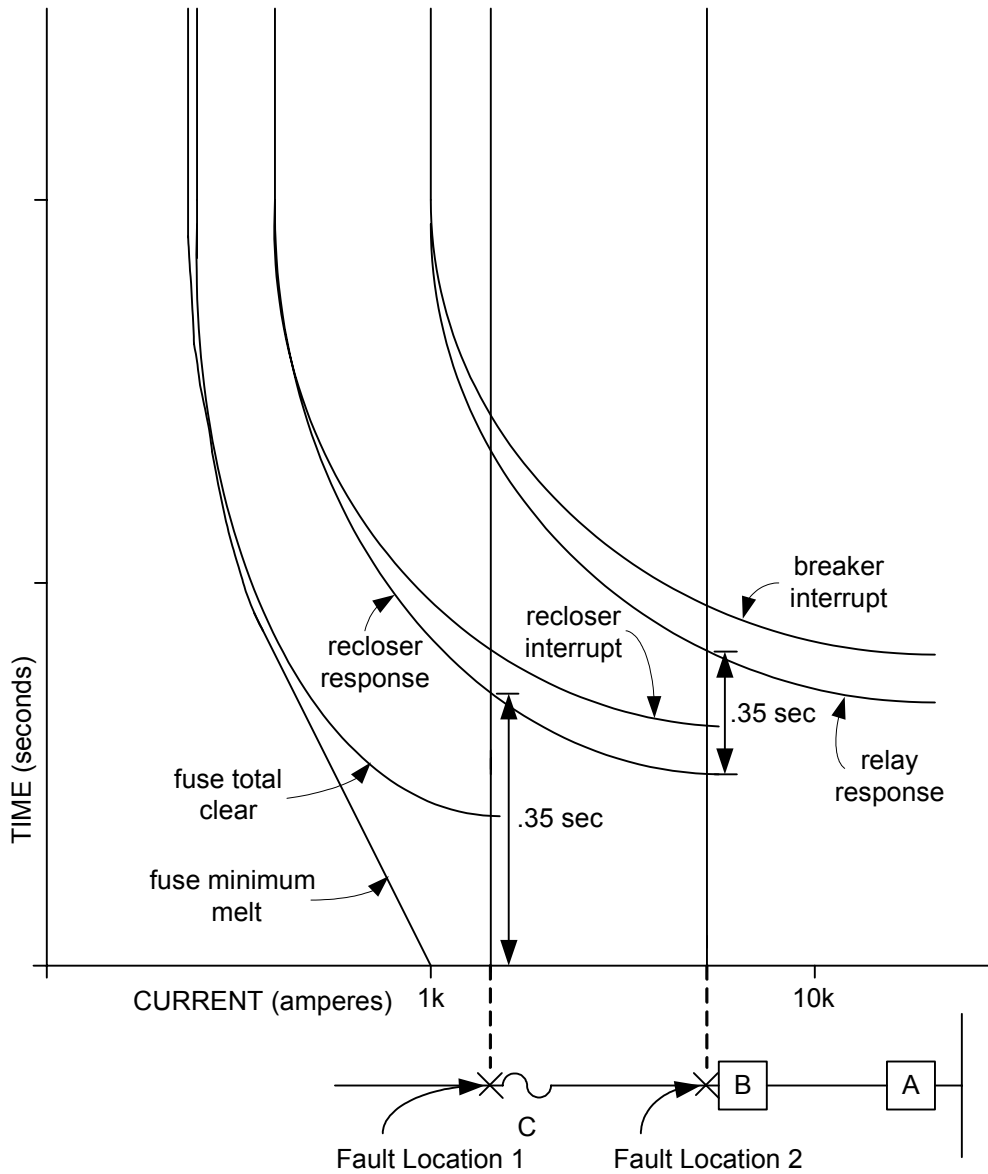

**Figure 7-5—Three-device coordination**

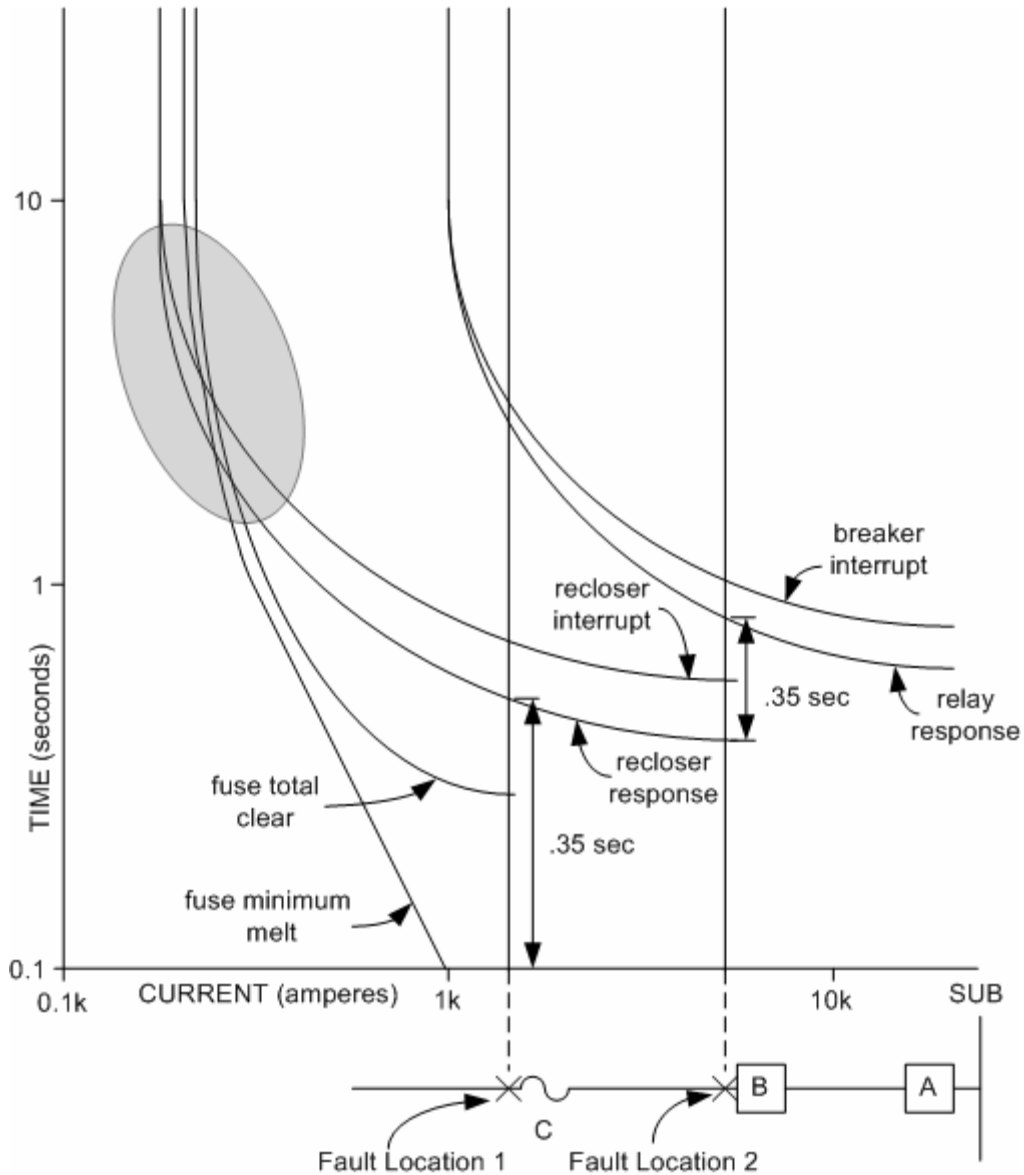

**Figure 7-6—Coordination between an inverse and extremely inverse device**

When coordinating overcurrent devices for phase-to-ground faults, both the phase and the ground elements of the protection device should be included in the coordination. The phase element on the faulted phase will be monitoring the same current magnitude as the ground element if there are no other sources for either positive- or zero-sequence current other than the substation source. The response characteristic for one fault interrupter is the composite of both the phase and the ground element's response to the fault. The critical characteristic is the faster of the two responses at each current level. Figure 7-7 demonstrates how both phase and ground elements are involved in the total response for both the relay-breaker and the recloser. The composite responses for both the relay and the recloser are marked on the diagram. All three phase elements and the ground element must be available when considering a composite response characteristic curve.

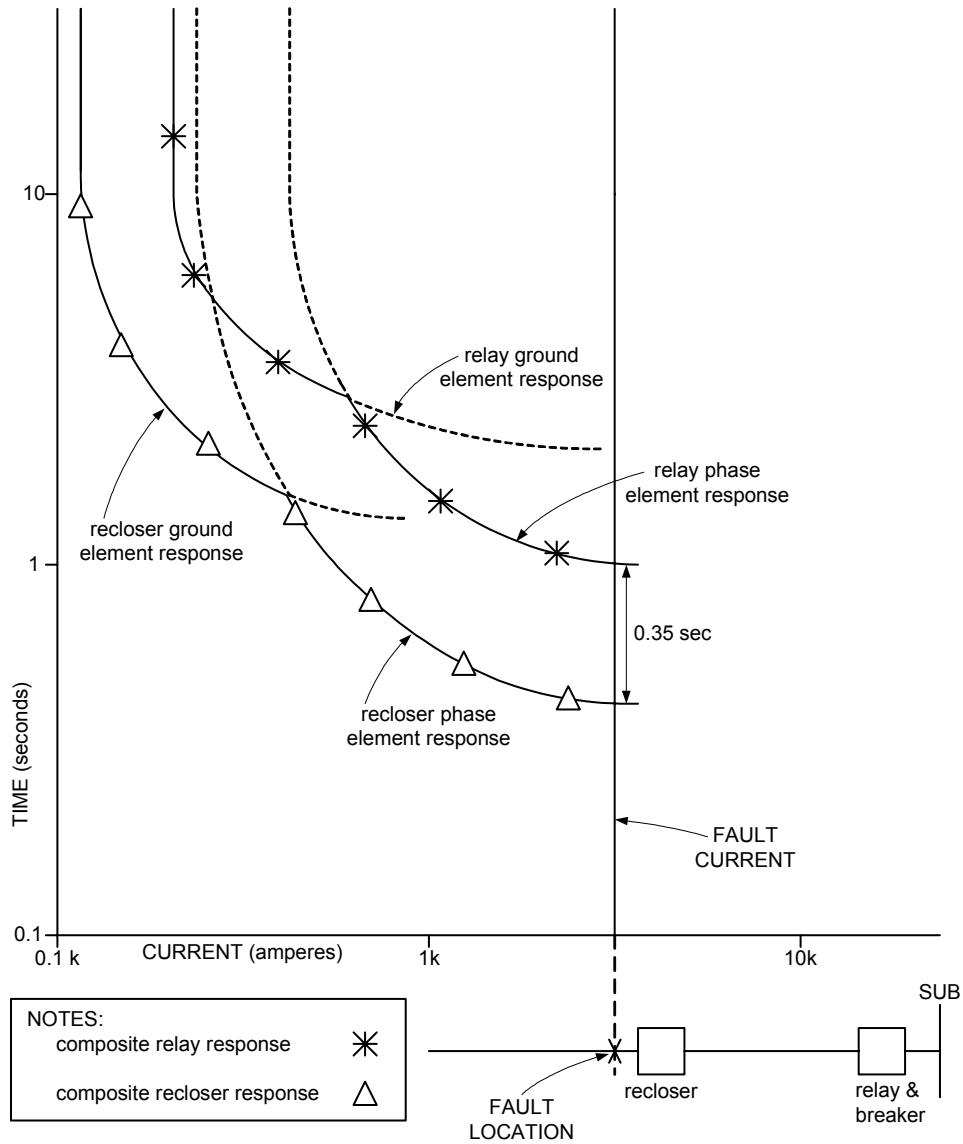

Figure 7-7—Coordination for phase-to-ground faults

One common coordination situation that occurs on distribution systems is the coordination between the feeder relays and the substation transformer overcurrent protection. The overcurrent protection on the high side of the substation transformer will not see the same magnitude of current for a feeder fault as the feeder relays do because of the turns ratio and winding configuration of the transformer. A common distribution substation transformer in North America has a high side delta winding and a low side wye winding with the neutral grounded. For this type of transformer, the high side overcurrent protection will see only the positive- and negative-sequence current for a line-to-ground fault on the feeder. For the same line-to-ground fault, the feeder relay will see the total of the positive-, negative-, and zero-sequence current on the bases of the low side voltage. To coordinate these two overcurrent protection devices for the ground faults requires comparing the response times of the two devices for the magnitude of current each will see for the same fault case. It is a common practice to draw the response characteristic of both devices on the same voltage basis, normally the feeder relay's base. This makes it easier to visualize the coordination. The transformer overcurrent device's response is shifted by the ratio of the amounts of current the two devices see for the same fault. For example, for a 138 kV delta – 12.5 kV neutral grounded-wye transformer, for a single line-to-ground fault on the 12.5 kV feeder,  $I_a = 9000$  A.

The sequence currents on the 12.5 kV side are  $I_1 = I_2 = I_0 = 3000$  A.

The sequence currents on the 138 kV side are:

$$I_1 = 12.5 (3000) / 138 \angle 30^\circ$$

$$I_1 = 271.7 \angle 30^\circ$$

$$I_2 = 12.5 (3000) / 138 \angle -30^\circ$$

$$I_2 = 271.7 \angle -30^\circ$$

$$I_0 = 0$$

On the 138 kV side:

$$I_a = 2 (\cos 30^\circ) 271.7$$

$$I_a = 470.6 \text{ A}$$

The ratio between the 12.5 kV phase current to the 138 kV phase current is  $9000/470.6$  or 19.12. A relay with a pickup of 100 A on the 138 kV side would have the equivalent pickup as phase overcurrent relay on the 12.5 kV side with a 1912 A pickup.

The tightest coordination for this configuration occurs for a phase-to-phase fault close in on the feeder. The ratio between the current that the feeder phase relay will see compared to the current the transformer high side phase overcurrent device will see is smallest for this fault condition. For the phase-to-phase fault, two phases on the 12.5 kV side will see 87% of the current for a three-phase fault in that location. But for the same fault, one phase on the high side of the transformer would see the same magnitude current as for the three-phase fault. If the phase overcurrent relays coordinate for the phase-to-phase fault on the feeder, the relays will coordinate for all fault conditions.

### 7.2.1 Different reset characteristics

Once the current through a time delay overcurrent device exceeds the pickup value for the device, it will start timing to the point at which the device will trigger the interruption of the current. If the current drops below the pickup value before the time delay is exceeded, the device will start resetting. Not all overcurrent devices reset at the same rate. Electromechanical relays reset at a rate based on the tension of the reset spring and the level of the current after the current drops below the pickup level. The longer the setting for the time delay to trip, the longer it will take for the relay to reset. Fuses store heat produced by the current passing through the fusible element. Once the current drops below the minimum operate value of the fuse it will start cooling. If the current is increased above the pickup value before the relay has reset or the fuse has cooled to the initial state, the overcurrent devices have a precondition toward operating. The relay will trip the circuit breaker and the fuse will blow in less time than if the devices had reset to the normal starting state.

Other overcurrent devices such as electronic and microprocessor relays have the option of an instantaneous reset. Once the current has dropped below the pickup level, they will reset, regardless of how long the overcurrent device has been timing. This difference in reset characteristics can help some coordination situations and cause problems for others. For two overcurrent devices operating in series on a system and if the device closest to the fault location has a time delay reset and the device closest to the source has an instantaneous reset, the difference in the reset methods will not affect the coordination between the two devices. If the devices are coordinated for the initial fault then after the reclose if the fault is still present the time between the characteristics will only increase. But if the device closest to the fault has an instantaneous reset and the backup device does not and if the reclose dead time was shorter than the reset time for the backup device there could be a coordination problem after the reclose if the fault is still

present. For this condition, one of three things needs to be done: 1) change the reset characteristic of the device closest to the fault to match the reset characteristic of the backup device; 2) increase the coordination time between the devices to compensate for the ratcheting action of the backup device; 3) increase the dead time between reclose attempts. Make the dead time long enough to allow the overcurrent devices to fully reset.

### 7.3 Clearing time

Fault-interrupting devices located in the substation and out along the distribution line generally are coordinated to minimize the number of customers that will be disconnected due to faults occurring on the line. The coordination process frequently entails adjusting the fault clearing times of the devices.

Long fault clearing times will adversely impact the power quality of the customers whose services are electrically close to the fault location, but are not actually interrupted. Customer equipment may be designed to conform to published standards concerning the ability of the equipment to properly operate during the voltage sag or swell that may be experienced during a distribution system fault clearing operation. These standards may provide the relaying engineer some insight into the impact that long fault clearing times may have on a customer. A graphical depiction of electronic equipment's voltage capabilities can be found in the Information Technology Industry Council (ITIC) curves as shown in IEEE Std 1100™-1999 (*IEEE Emerald Book™*) [B39].

The system shown in Figure 7-8 illustrates the effect of fault clearing on customer service. The source impedance, including the impedance of the substation transformer, is  $0.7 \Omega$ . Feeder 1 has 200 customers connected to it. Feeder 2 also has 200 customers, but the customers are divided into two equal groups by a recloser that is mounted 2 km away from the substation. The impedance of the line to the recloser is  $1.0 \Omega$ . The second section of Feeder 2 is also 2 km long but has smaller conductor than the first line section. The total impedance of the second section is  $1.5 \Omega$ . The customers' loads are connected at 20 m intervals along all line sections.

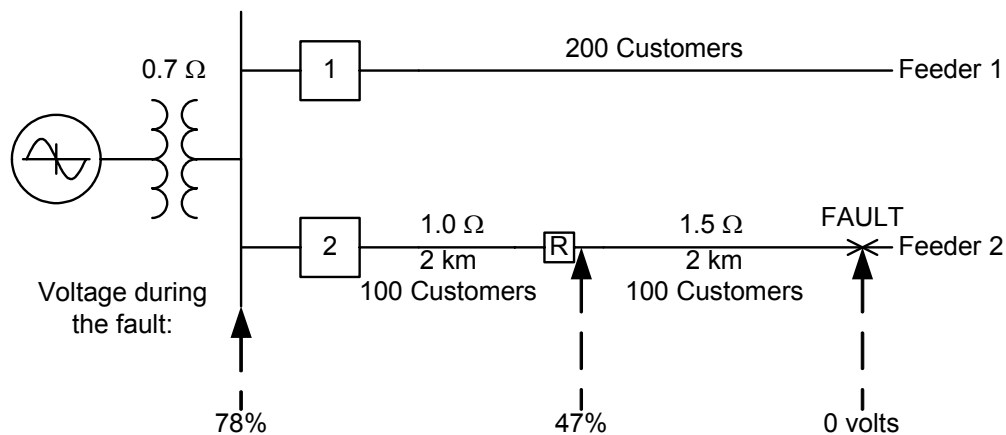

Figure 7-8—Effect of fault clearing on customer service

For a three-phase fault at the end of Feeder 2, the line recloser is intended to isolate the faulted section, and as a result, causing an interruption of service to 100 of the 200 customers on the line. Based on the ITIC curves, if the line recloser cleared the fault in 0.1 s, 64 of the customers on the main section of Feeder 2 and all the customers on Feeder 1 would probably not encounter equipment problems due to the voltage sag experienced during the fault. If the line recloser cleared the fault in 0.3 s, all of the customers on both feeders would experience a voltage sag whose duration may exceed the capabilities of the equipment to operate properly through the voltage sag.

## 7.4 Reclosing (79 function)

Reclosing relays automatically reclose circuit breakers after tripping by fault detecting relays. Automatic reclosing is applied because the majority of faults on overhead distribution systems are temporary in nature. These faults may be caused by factors such as lightning induced insulator flashovers, animal or tree contact to the energized line, or by wind causing conductors to move together and flashover. These feeders can be effectively restored after deenergizing the faults long enough to allow the fault arc to deionize. Reclosing elements automatically reclose the feeder breakers to attempt to restore the feeder after these temporary faults.

Reclosing is almost universally applied on overhead distribution feeder breakers, and often applied on circuits with some underground sections. Reclosing is generally not applied on feeders with no overhead exposure, because faults on underground feeders are generally permanent. The reclosing function may be implemented as part of a numeric relay system, or as a separate relay with inputs from the fault detecting/tripping relays.

Reclosing relays (or relay elements) will initiate a sequence of between zero and three close attempts with settable time delays between operations. If the fault remains throughout the reclosing sequence, the reclosing relay will go to lockout, and block further closing attempts. If, however, any reclose attempt is successful (temporary fault is cleared), the reclosing relay will return to its initial state, after a reset time.

Issues relating to autoreclosing are discussed in the remaining subclauses. A more detailed discussion of autoreclosing issues can be found in IEEE Std C37.104™-2002 [B46].

### 7.4.1 Reclosing initiation

A reclosing attempt should only be initiated when the breaker has opened due to a fault on the protected feeder. This is generally accomplished either by using an open breaker status or a Reclose Initiate signal from the fault tripping relay or element. When using the breaker status, the breaker will reclose if the control switch is in auto. If using a Reclose Initiate signal, the reclosing relay or element will look for an open breaker status (often detected with a breaker status contact, such as 52b) in concert with the Reclose Initiate signal. Manual or supervisory trips should not initiate reclosing attempts. More complex protective schemes may prevent reclosing for certain tripping conditions, such as a high-set instantaneous overcurrent trip, a multi-phase fault trip or a trip on an underground cable circuit.

### 7.4.2 Fault clearing time

A reclosing scheme should allow enough time for the arc to deionize before initiating a breaker close. For distribution applications, experience shows the deionizing time will be less than 11.5 cycles ( $t = kV / 34.5 + 10.5$ ). Deionizing time will be longer if single pole tripping is applied.

### 7.4.3 Open interval and number of attempts

Reclosing schemes will usually incorporate several reclosing attempts, with time delays between attempts. The speed and number of reclosures is determined by individual utilities. Some utilities may use one fast and one or two time delayed attempts. The first reclose attempt may have no intentional time delay) or have a small (<5 s) time delay. Subsequent reclosing attempts will have longer delays, perhaps 15 s to 30 s.

### 7.4.4 Reclosing with low magnitude faults

Low magnitude faults may have fault clearing times longer than the reset time of the reclosing relay. This can lead to unlimited reclose attempts for a permanent fault, as the reclosing relay never reaches lockout. This situation can be addressed by applying a reset wait function. The reset wait function will stop the reset timer when a protective element is picked-up and timing towards trip. This will prevent the undesired reset during a fault sequence, without forcing unreasonably long reset times. Another method is to enable the fast tripping overcurrent functions, in a fuse saving scheme, just before resetting of the reclosing function.

## 7.5 Cold load pickup

A significant portion of a distribution feeder's load will be intermittent loads, such as air conditioners, electric heaters, and refrigerators. These loads will cycle on and off at differing intervals, so that, under normal conditions, only a portion are on at any given time. After extended feeder outages, however, this load diversity is lost. Consequently, when the feeder is reenergized, all (or most) of these loads will be switched on. This can cause a significant surge in load current, which may be in excess of time overcurrent pickup levels. This condition is known as cold load pickup. The additional load will decay over a comparatively long time (by relaying standards), perhaps 30 min or more. Figure 7-9 shows a generic representation on a cold load pickup event. The pre-outage load current on the feeder is around 30% of the pickup level of the associated overcurrent relay. At 15 min into the chart, a load interruption occurs, and the load current drops to zero. In this example, the outage lasts 25 min, during which some degree of load diversity is lost. When the circuit is restored (at 40 min into the chart), there will be a current surge. The initial inrush current will include the starting current for all of the connected motors. This initial inrush may only last a few seconds, and is not visible in Figure 7-9. After the initial inrush period, the feeder will be more heavily loaded, as a larger than normal percentage of the cyclical loads will be on. Over some time period, the load diversity is regained, and the load will decline back towards the normal load level. The rate at which load diversity is lost, and regained, depends on a variety of factors, including ambient temperature and insulation ratings of buildings with heating or cooling loads.

Distribution relay schemes should take cold load surges into consideration. The simplest method would be to set overcurrent pickups above the worst case cold load current, to ensure security. This decreases sensitivity, however, and may limit the ability to see end-of-zone faults. Alternately, the feeder can be segmented, to pick up load in portions. This allows the overcurrent relays to be set sensitively, but extends outages. Numeric-based relay schemes can use adaptive capabilities to switch into alternate setting groups when cold load conditions are detected. This allows more sensitive overcurrent settings during low load conditions, while allowing security for cold load situations.

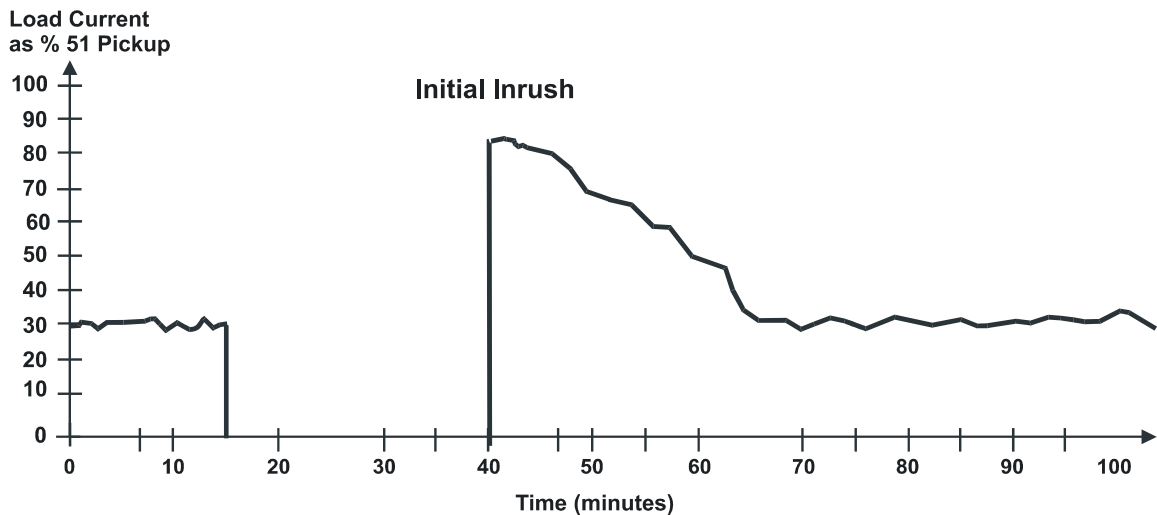

Figure 7-9—Cold load pickup

## 7.6 Adaptive relaying cold load

Adaptive relaying can be used to avoid trips that could occur due to temporarily high cold load pickup currents. The dropout, or deassertion, of a load detecting overcurrent element in the relaying scheme can be used to signal the absence of load current in a distribution feeder's circuit breaker. The position of a device in the substation could be used to signal a loss of load condition. The load detecting overcurrent element is often utilized to account for the situations where the loss of load condition may be due to the loss of the

station's transmission system source due to the operation of a device in another location. The loss of load may also occur due to the opening of a downstream device such as a line recloser. When the source is reestablished or the downstream device is closed, the resulting inrush of temporarily high load current could exceed the pickup setting of any sensitive overcurrent elements intended to detect fault conditions.

The loss of load condition, after a time delay, can be used to temporarily remove the sensitive element that may be prone to trip from service. The loss of load condition could be used to insert, or lengthen, a time delay to operation of the sensitive overcurrent element. It may be preferable to have the adaptive scheme execute a settings change that will decrease the sensitivity of the element of concern.

## 7.7 Fuse saving

Fuse saving is a scheme that takes advantage of the fact that most faults on distribution circuits are temporary. For this scheme, a low-set instantaneous relay (50LS) is applied and set very sensitively, to trip for any faults on the entire feeder. Figure 7-10 shows the 50LS element will over-reach downstream fuses, and trip the entire feeder for faults on fused branches. After one or more reclosing attempts (indicating a permanent fault), the low-set instantaneous element is blocked, and the branch fuse is allowed to blow. Fuse saving schemes avoid unnecessary extended outages on fused branches for temporary faults, but increase the momentary outages over the entire feeder. Recent data in "Distribution Line Protection Practices Industry Survey Results" [B31] shows that fuse saving is used by a majority of utilities, but may be declining in popularity.

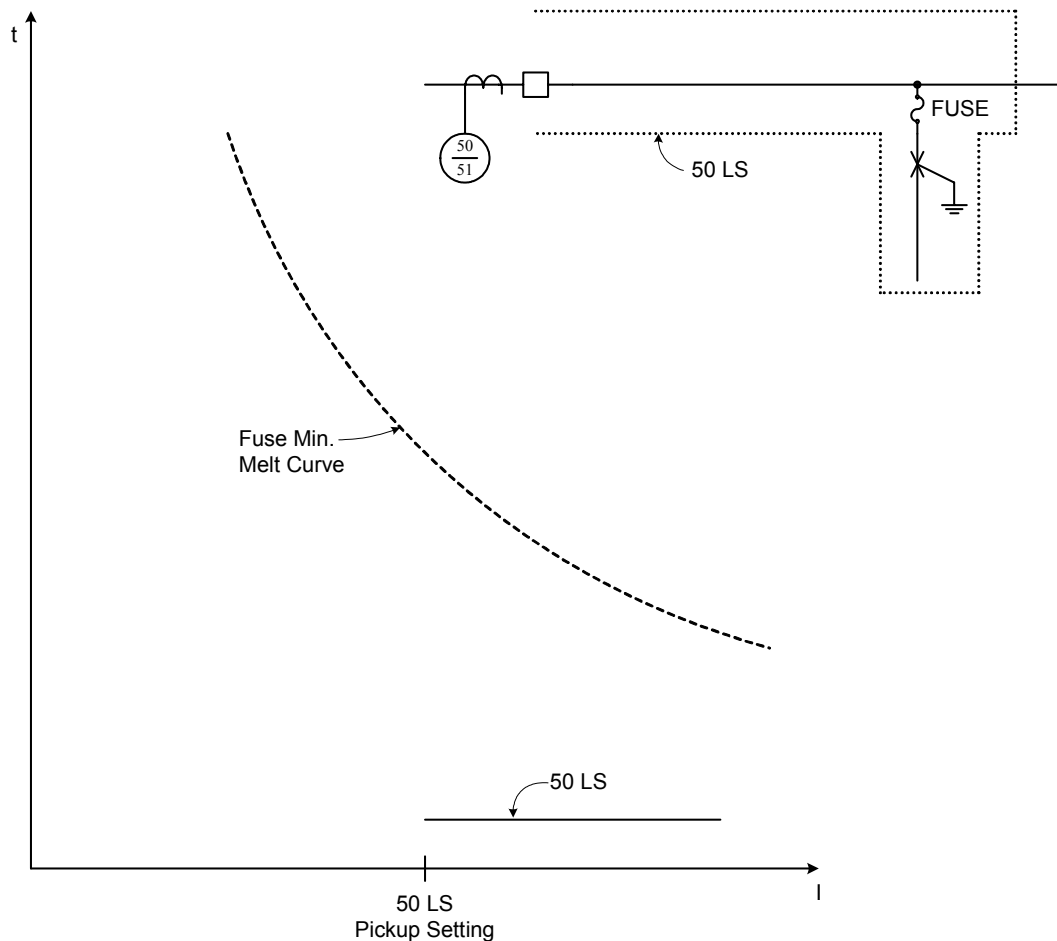

**Figure 7-10—Time coordination between low set instantaneous (50LS) and downstream fuse**

## 8. Special applications

### 8.1 Parallel lines

In this case, system configurations are such that multiple feeder breakers are served from a single point source. In some instances, the distribution circuits are on the same structure and/or in close proximity with each other due to normally opened connecting air switches. When the actual facilities are configured in this manner, the probability of multiple circuits being involved in a single event can be relatively high. This is especially true if instantaneous relaying is not applied.

In these situations, the fault may begin on one circuit and slowly evolve to the other circuit, it may begin on one circuit and quickly evolve to the other circuit, or it may essentially simultaneously involve both circuits. The single point source detects the entire fault current for the entire duration. Each feeder breaker only sees a portion of the fault current only for the time that the particular feeder breaker is closed. Figure 8-1 illustrates this type of situation. The entire fault current ( $I_F$ ) is detected by Circuit Breaker 1 (CB1) while only a portion of the current is seen by each feeder. To ensure proper coordination, either sufficient coordination margin should be obtained or higher order relay integration employed.

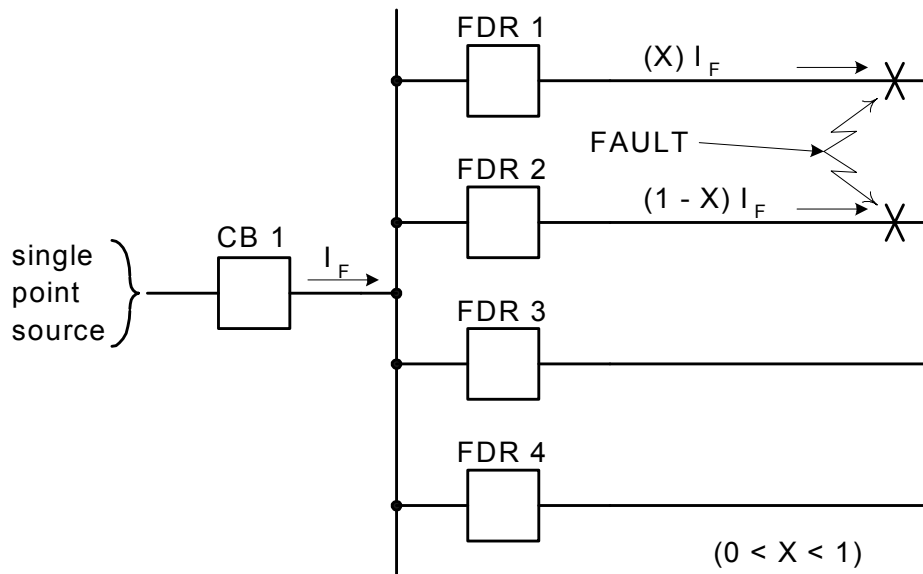

Figure 8-1—Faults involving two circuits

To ensure proper coordination margins for each of these three fault scenarios, separate studies can be run. A general rule of thumb would be to apply the normal coordination margins with the feeder breaker sensing 50% of the bus fault current level current and the single point source sensing 100% of the bus fault current level.

Another method to accomplish proper coordination is to design the relay system such that the single point source relaying is integrated with the feeder breaker relaying. For instance, any time more than one feeder breaker is above a pickup current level, enabling or disabling of certain selected source relay elements can be employed or the source relaying could be prevented from operating.

### 8.2 Automation

In an attempt to facilitate the rapid response to outages as well as the efficient day-to-day operation of the distribution system, some utilities have begun the implementation of DA (Distribution Automation) into the

design of their distribution circuits. DA allows the operator to remotely or locally operate various sectionalizing switches, breakers, and reclosers. DA also supplies the system operator with real-time data (voltage, amperage, power flow, etc.) of each circuit by remotely monitoring the analog values made accessible by the RTUs (remote terminal units) at each DA equipped device. The system operator also has the ability to monitor the status points of these devices. The ability of DA to provide all this data allows quick determination of which portions of a circuit are experiencing problems. With this knowledge, the operator can perform remote control or dispatch operating personnel who can isolate and restore portions of the circuit. This reduces the number of customers who will be out of service until full repairs can be made. Some DAs feature advanced capabilities such as disturbance direction detection that can immediately troubleshoot by characterizing a disturbance as upstream or downstream with an indication that can be shown in an active alarm window, on-board event log, and e-mail or error-checking/correction HTML page. Other advanced capabilities include alarm set-point learning, which allows DAs to learn normal operating ranges for specified alarm quantities then recommend or automatically configures alarm set points with minimal end user involvement, and sequence of events Recording (SER), which provides high speed time stamping of system inputs to within 1 ms resolution.

Circuits are generally designed with a peak expected load in mind. As areas grow within the load boundaries of a particular circuit, the peak loads may exceed the built in load limitations of the circuit. This affects the system flexibility to tie, separate, or transfer load remotely or by local control. DA then becomes a tool for the operator to control the system configuration with greater speed and ease.

In the event of a storm, DA can provide automatic sectionalizing as well as remote operation of equipment to further sectionalize circuits to reduce the number of customers affected by the storm. There is also the ability to pick up unfaulted portions of circuits by remotely tying those portions to other circuits.

A loop scheme is another method that is used by utilities to improve reliability. A loop scheme is typically applied to two circuits by installing a normally opened tie recloser at a tie point between two circuits. Also, a normally closed sectionalizing recloser is installed on each circuit. See Figure 8-2.

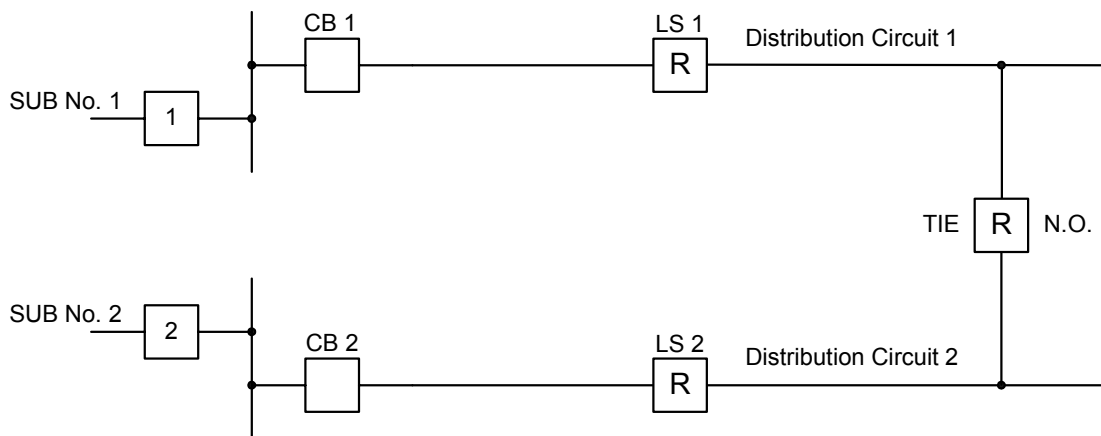

**Figure 8-2—Loop scheme**

The three phase reclosers monitor the three-phase voltage. A simple description of how the loop scheme shown in Figure 8-2 works is as follows. Assume that CB1 (circuit breaker 1) opens for a fault between devices CB1 and LS1. The loop scheme sectionalizing recloser, shown as LS1, will sense a loss of voltage and will open and lock out after a preprogrammed time interval. The tie recloser will also sense loss of voltage, and it will close after the LS1 recloser opens, therefore automatically restoring a portion of Distribution Circuit 1. Note that the protection settings at the SUB Main Breaker and at the CB and LS should be set to account for the maximum load added when the tie recloser closes to maintain selectivity.

Otherwise, a second setting group for the combined load could be automatically selected by the tie closure. Loop schemes can restore even more customers if they are operated in conjunction with sectionalizing switches. Figure 8-3 shows how the system with sectionalizing switches will work.

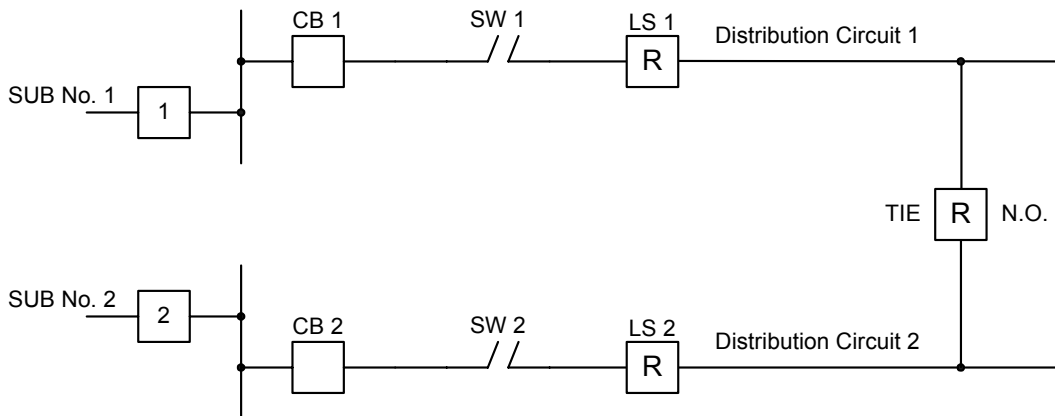

**Figure 8-3—Loop scheme with sectionalizing switches**

Assume that there is a permanent fault on Distribution Circuit 1 between LS1 and CB1. The relaying associated with circuit breaker CB1 will cause it to open. The loop scheme sectionalizing recloser LS1 will sense loss of voltage and open. The tie recloser TIE will sense loss of voltage and close. Part of Distribution Circuit 1 is now restored. However, if it can be determined that the fault was between SW1 and circuit breaker CB1 then SW 1 can be opened either remotely or manually. The loop scheme sectionalizing recloser LS1 could be set to coordinate with the tie recloser for faults on Circuit 1 between LS1 and SW1 and then LS1 can be closed in order to restore customers between LS1 and SW1. This way more customers can have their service restored quicker. Additional studies will need to be performed to ensure coordination of the fault detection devices for both the normal and the abnormal operation of the circuit, and that overloading will not occur. If the load permits, then LS1 can be set selective with the TIE and LS1 will provide protection up to SW1. The four LS1 load circuit scenarios for protection selectivity study are as follows:

- Distribution Circuit 1 (TIE open)
- Distribution Circuits 1 and 2 (TIE closed, LS2 open)
- SW1 to LS1 customers (SW1 open)
- Distribution Circuits 1 and 2 plus SW2 to LS2 customers (TIE closed, LS2 closed, SW2 open)

Some loop scheme reclosers that allow for remote setting changes and multiple setting groups may be employed effectively.

For faults between LS1 and TIE, additional logic is required at the TIE point to mitigate the case where the TIE could close into a fault.

The added flexibility of DA enables utilities to respond to outages in a more effective and expedient manner. With the help of highly developed technologies, intelligent devices installed on the distribution system can communicate among each other and automatically sectionalize to isolate the faulted section.

### 8.3 Load shedding

The objective of underfrequency load shedding is to arrest system wide frequency decay after a disturbance to the system such as a loss of a transmission line or generation source. The objective of undervoltage load

shedding is to unload a system that is on the verge of collapse due to a shortage of reactive power support. It is up to the interconnected utility to perform sufficient dynamic stability studies to determine where and how within their system the load will be shed. If the frequency is decaying slowly, the system operators may make the decisions on which loads to shed. However, if frequency is decaying rapidly, the load-shed scheme should be automatic to drop sufficient load in a short period to balance load with generation. In extreme cases, the load-shed relaying may need to match load with generation in an islanded system. In other cases islanding the utility, if it has sufficient internal generation capacity, may be the only way to protect it from collapse with the interconnected system.

Most automatic frequency based load-shed schemes are activated by individual frequency relays, which trip large industrial load centers or individual feeder breakers. Most automatic voltage based load shedding schemes are activated by individual undervoltage relays, which trigger the disconnecting of the load. Most modern relays allow several set points to be input allowing one relay to trip several feeder breakers in specified steps. Set points for tripping vary from utility to utility or for the requirements of the control area's council. Automatic frequency tripping steps range from 0.5 Hz to 0.2 Hz. Some modern under frequency schemes utilize rate of frequency change rather than frequency magnitude for the set points. For more details on under frequency relay applications and settings, please see IEEE Std C37.117™-2007 [B49].

## 8.4 Adaptive relaying schemes

Adaptive relaying is making automatic real-time adjustments to power system protection schemes to achieve the most dependable and secure distribution system protection for the system conditions at that time. In addition to adaptive relaying schemes, often SCADA signals are used to remotely change the protective scheme or reclosing settings based on the desires of the system operator.

### 8.4.1 Traditional adaptive schemes

Traditional distribution protective schemes have used fairly basic adaptive relaying. For example, one of the oldest methods of adaptive relaying was to alter the tripping time on a protective relay or service restorer based on when the trip operation occurs in relation to the reclose sequence. For instance, the first two circuit trips might operate relatively fast, and if the breaker reclosed into a fault, the tripping curve could be altered to allow the device to operate more slowly. This would allow downstream fuses to ride through the first operations but to blow if the fault was still on the system. This type of scheme is often defined as a fuse saving scheme because for most transient faults, fuses are not required to operate.

### 8.4.2 Adaptive relaying using microprocessor relays

Numerical distribution protection relays with multiple settings groups provide the capability to adapt protection settings, control schemes, reclosing schemes, and protection elements by changing settings groups and tripping matrixes. The relays adapt based on decisions made by internal logic, by analog quantities that it measures, by communication with other relays or intelligent electronic devices, and/or by monitoring the status of switches and/or circuit breakers.

While most distribution circuits do not require this form of adaptation, present protective relaying capability allows tremendous flexibility to adapt the operation of the relay for changing load, load unbalance, cold load pickup, fault type, and/or system configuration changes.

## 8.5 Multiple faults

Distribution protection application should consider multiple faults occurring nearly simultaneously as often occurs during major wind, lightning, or ice storms. If this were to occur on the system depicted in Figure 8-2, it is possible that the coordination could be lost between the relays associated with CB1 and the relays associated with the other circuit breakers shown in the one-line. For instance, if a fault started on FDR1 and before FDR1 tripped, a fault began on FDR2, and before FDR2 tripped, a fault began on FDR3, it is

possible that CB1 would trip prior to FDR3 tripping. To reduce the likelihood of this type of misoperation occurring, wide coordination margins or integrating the substation relaying as described in 8.1 should be used.

Additionally, it is important that the reset characteristics of the relays associated with CB1 be quicker than that of the relays associated with the other breakers shown on the one-line. This is true of both electromechanical and solid state relays. If the reset characteristic of the relays associated with CB1 is slower than that of the relays associated with the other breakers on the one-line, there is a higher probability of miscoordination due to multiple faults.

Another method to reduce the likelihood of the CB1 relay misoperation due to multiple faults is to delay the automatic reclosing on breakers FDR1, FDR2, FDR3, and FDR4. This delayed reclose often will allow the relays associated with CB1 an opportunity to reset prior to the feeder breaker closing into a fault.

## 8.6 Sympathetic tripping

Sympathetic tripping problems are primarily dependant on the characteristics of the loads connected to a distribution system. As faults occur on a distribution line the magnitudes of the faulted phases' voltages are depressed at the source substation bus. In addition to this magnitude change, the faulted phases' voltage phasors swing to a different phase angle relationship compared to the pre-fault voltage phasors.

As the bus voltages are restored to nominal magnitudes and expected phase angles after the fault is cleared, load currents tend to increase on the phases that experienced the voltage depression. This increase in current relative to the pre-fault load current magnitudes can persist for several cycles.

A feeder that shares its source bus with the faulted feeder may experience high enough post-fault load currents to trip sensitive protective device overcurrent elements. On heavily loaded systems, this sympathetic tripping may also include the relaying associated with the source transformer bank.

Maintaining a margin between the maximum loads a feeder is anticipated to carry and the sensitivity of protective elements is the best solution to avoid sympathetic tripping of unfaulted feeders and transformer relaying.

## 8.7 Distributed resources

Technological advances have been coupled with a favorable economic environment resulting in a number of small generators being installed on distribution systems. These generators on a distribution system are referred to as distributed resources or DRs. A DR is installed to realize many benefits such as reliability, efficiency, and power quality. For example, some utility distribution companies and utility customers use DRs to improve utility operations and customer service. However; when DRs are integrated on radial or networked power systems originally designed to only serve load, they may require modification of the feeder protection. The requirements for interconnecting these DR must be determined during their project planning stages, see IEEE Std 1547-2003 [B40]. For DR applications, it is beyond the scope of this guide to address consensus methods used for performing impact studies, mitigating limitations of the utility distribution system, or for addressing business or tariff issues associated with DR interconnections. However, the main issues for DR and utility distribution system protective relaying are as follows:

- Protective device coordination
- Auto-reclosing
- Issues of islanding DR with local loads
- Grounding

These major issues have many related concerns such as safety, equipment ratings, training, and impact on other customers that should also be considered.

### 8.7.1 Protective device coordination

The presence of DR will affect protective device coordination in different ways depending on the locations of the devices and the DR. The most obvious concern is for the coordination of upstream devices on the radial circuits containing the DR. The coordination of downstream devices, coordination on adjacent circuits, and substation transformer backup protection should also be considered. The type of connection used to attach the DR to the system will determine whether the distribution coordination is affected. For example, if the DR transformer has an ungrounded wye or a delta connection to the feeder, then there will not be any contribution to common ground faults and coordination will not be affected. However, this arrangement will make it difficult to detect single phase-to-ground faults on the system at the DR and can cause other problems not related to protective relay coordination (see IEEE Std 1547-2003 [B40] and “Impact of distributed resources on distribution relay protection” [B33]). For the purposes of discussion on coordination effects, it can be assumed that the connection and fault type are such that the DR will contribute.

Consider the system of Figure 8-4. It can be expected for protective devices on the circuit beyond the DR that the available current for faults at  $F_1$  will be greater. This will result in more circuit coverage from the protective device, which may or may not be desirable. The device coverage may extend through additional lateral circuits and possibly require greater operating times to coordinate. Coordinating devices on the upstream side of the DR connection will be subject to infeed effect, which will result in a larger coordination interval.

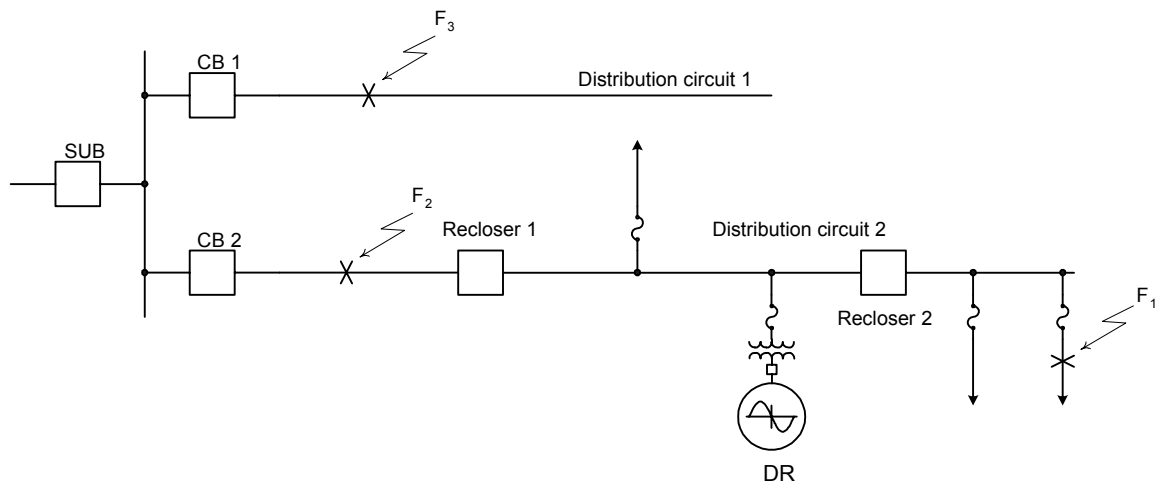

**Figure 8-4—Distribution with DR**

Faults such as  $F_2$  that are upstream of the DR will cause reverse current to flow in Recloser 1 in Figure 8-4. This could cause confusion for sectionalizing schemes if a device downstream of the fault is tripped and delays restoration of customers' loads for temporary faults. Since it is normally not desirable to island the DR with other customers' load, the protection on the DR needs to be coordinated with Recloser 1, so the DR is disconnected before Recloser 1 has a chance to operate.

The fault  $F_3$  located on the adjacent feeder will show effects similar to both of the previous faults. The magnitude of fault current on the circuit will be greater for the entire circuit. The current at breaker CB 2 will be reversed. If the relay protection at breaker CB 2 is not coordinated with breaker CB 1, the result will be the unnecessary trip of circuit 2. This coordination can be further complicated if more than one circuit contains DR. Backup protection from the substation breaker may have trouble with coverage of circuit 1 due to infeed from circuit 2.

It is clear that if the existing line protection is left in place, the coordination should be evaluated for each substation feeder circuit. Changes to the existing protection to accommodate the DR will usually result in longer delays in tripping and reclosing operations. In some cases, sequential operation or miscoordination may have to be considered. Delayed operations, sequential operations and miscoordination represent a degrading of the power quality to other customers on the circuit that could be unacceptable. Consequently, the need to make changes to the line protection systems to accommodate the DR can create additional concerns.

#### **8.7.1.1 Protective device communications**

The simplest solution to protection problems arising from the addition of DR to the circuit is to trip the DR any time a fault is detected on the circuit. Sensing for the fault may occur at the DR point of connection; but the primary sensing, for feeder protection, is at the circuit source (breaker CB 2 in Figure 8-4). Concerns include the reliability of the transfer trip circuit, the future coordination of the maintenance or replacement of that equipment, and the loss of flexibility in the operation of the distribution system. This loss of flexibility is a concern both for future load growth and for abnormal operating situations. If the DR is transferred to another circuit, either temporarily for maintenance or permanently for load growth, the transfer trip equipment would need to be moved or duplicated on that circuit. The transfer trip may be required due to islanding considerations as discussed in 8.7.2. Refinements can be made to this scheme using the communications to prevent tripping for faults downstream of the DR connection that can be cleared by an appropriate device, such as Recloser 2 in Figure 8-4.

#### **8.7.1.2 Directional relays applied to DR**

Another solution to the coordination problems created by the introduction of DR to the circuit is to install relays capable of sensing direction. This may take the form of impedance-type relays or directionally polarized overcurrent relays or a combination. Although this will solve some of the coordination problems, there are some drawbacks to consider. The directional relays may be more expensive than the existing relays, and they may require the addition of VTs. This type of relaying is different than what is normally used on distribution and may require additional training.

#### **8.7.1.3 Reclosing with DR**

The presence of DR will require a study of reclosing. Installing a DR on the circuit may require added delays to reclosing that affect other customer loads on the circuit. It is desirable to minimize this impact. Fault  $F_2$  lies between the substation and the DR. The main issue in reclosing following the trip for such a fault is to determine how much to delay the reclose time; instantaneous recloses are not used. If the DR output is significantly mismatched with the load, islanding cannot occur and the DR will trip whenever the source is lost. The reclose time must allow for the DR tripping time.

### **8.7.2 Islanding**

When a DR is present on a radial distribution system, there may be conditions under which the generator can support the distribution circuit load if the distribution source breaker is opened. Once the breaker opens, the circuit with the DR is considered an island. Unintentional islanding is always a concern for DR applications. IEEE Std 1547-2003 [B40] provides the unintentional islanding requirements as well as some guidance to meet the requirements. If the mismatch between load and generator output is great enough, the interface protection at the DR connection will cause the DR to trip. Where direct transfer trip is to be used for protection against unintentional islanding, some utilities may require the addition of voltage-check and synch-check to the substation reclosing as redundancy to the transfer trip. Transfer tripping the DR needs to be coordinated between the DR and the utility and that may help shorten the duration of the circuit reclosing delay.

Because of operational and safety issues, intentional islanding is rarely permitted by the utility without extensive analysis. If the DR is planned to remain in service during an islanding condition, the oscillations

of the DR in response to a disturbance may result in undesirable voltage flicker. There is no consensus standard for planning DR islanding applications, but guidance is provided in IEEE P1547.4™ [B41].

### 8.7.3 Grounding

For most of the protection issues concerning DR already discussed, it was appropriate to consider the grounded wye connection to the system. If the DR connection is ungrounded wye or delta and the utility (grounded) source is opened; then the circuit will become ungrounded. If this occurs during a line-to-ground fault, then the DR interface may not detect the fault and respond correctly. If islanding occurs, then serious overvoltages may result, which will damage utility and customer equipment and create a safety concern. In this case, direct transfer trip or voltage unbalance detection will be required to assure the DR is removed from the circuit.

## 8.8 Communications

### 8.8.1 Introduction

Historically, the use of communications channels in protective relay schemes on distribution circuits has been limited to applications such as direct transfer trip or remote control. As the design of distribution circuits has changed in response to increased reliability and power quality requirements, the use of communications channels to enhance the speed and dependability of the relay protection schemes has also increased. Relay communications channels for distribution circuit protection have been successfully implemented via direct connection to copper or fiber optic cables, leased telephone circuits, and point-to-point radio. Selection of the communications channel and medium often depends on the speed, security, and dependability requirements of the proposed protection scheme versus the type and cost of the communications infrastructure available where the protection scheme is physically located.

### 8.8.2 Direct transfer trip

When a DR is present on a radial distribution system, there may be conditions under which the generator can support the distribution circuit load at full or reduced voltage and frequency if the distribution source breaker is opened. In the case of parallel generation, a direct transfer trip (DTT) scheme can be used to ensure safe isolation of the generator before any attempt is made to reclose the source breaker (see “Myths of Protecting the Distributed Resource To Electric Power System Interconnection” [B13]). In Figure 8-5, a generator is shown connected to a radial distribution circuit. The protective relays at the 12.5 kV distribution breaker at Substation A are typically non-directional phase and ground overcurrent relays set to coordinate with the largest or highest-set protective device on the distribution circuit. If the breaker is equipped with automatic reclosing, the reclose interval would be similar to that applied to any other radial overhead distribution circuit except that the first reclose is typically delayed instead of instantaneous. This is done to allow ample time for both the DTT scheme and the high-side recloser at the generator to operate and disconnect the generator from the line before any attempt is made to reclose the breaker.

The communications channel in Figure 8-5 is required solely by the DTT scheme. If the 12.5 kV breaker at Substation A trips for a fault or is opened manually, a “52b” contact from the breaker keys direct transfer trip transmitter DTT Tx so that a direct transfer trip signal will be sent to direct transfer trip receiver DTT Rx to open the recloser or breaker at the generator step-up transformer. Because the generator on the 12.5 kV distribution circuit cannot supply fault current through the wye-delta Substation A transformer for a single phase to ground fault on the 138 kV system, it may still be on line (possibly at a reduced voltage) if the 138 kV line breakers trip. Therefore, a 27/59 relay is installed on the 138 kV side of the transformer to detect the phase to neutral voltage drop or rise on the 138 kV system during a single phase-to-ground fault on the 138 kV line. The 27/59 relay keys the DTT Tx to ensure that the generator is disconnected before either of the 138 kV line breakers reclose.

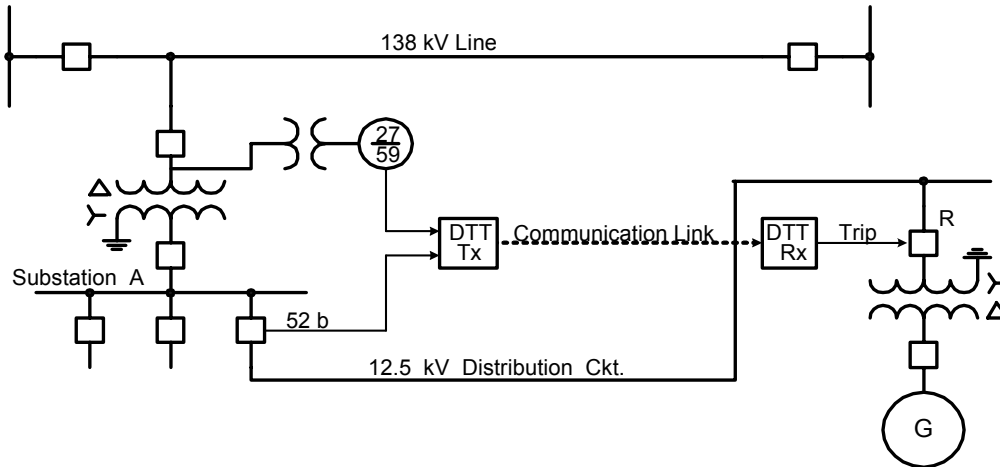
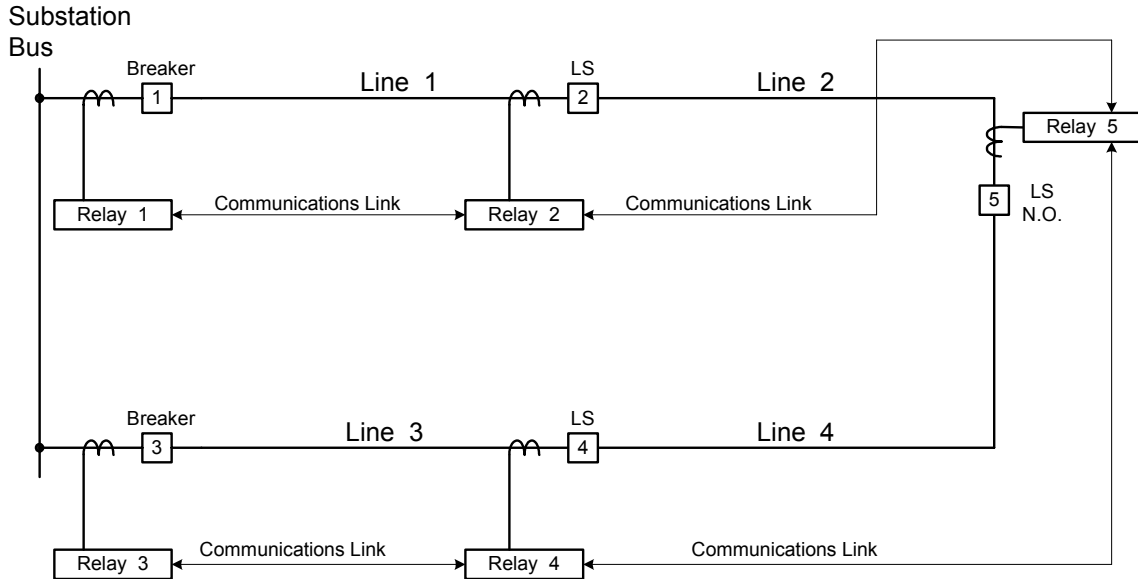

Figure 8-5—Direct transfer trip scheme on a radial distribution circuit

### 8.8.3 Communications-enhanced trip and restore

A microprocessor-based relay with the ability to communicate with other relays or intelligent electronic devices can be applied to improve the speed and selectivity of tripping and the continuity of service to customers served from radial or looped-radial distribution circuits (see “Trip and Restore Distribution Circuits at Transmission Speeds” [B62]). A simple looped-radial distribution system is shown in Figure 8-6 consisting of two circuit breakers and three line switches (LS) connecting several sections of distribution line. The line switches typically do not have fault current interrupting capability, and one of the line switches is usually operated normally open. The breakers and line switches are all equipped with relays. The relays are connected together through a communications link to enable them to share system data and breaker or line switch status between them. Logic is then developed in the relays to enable them to determine the location of a line fault and to trip the appropriate breakers and line switches to isolate the fault. Once the fault is isolated, the relays can selectively close the appropriate breaker or line switch based on the equipment status and system condition data received over the communications link to automatically restore all but the faulted line section to service. The ability to communicate enables the relays to provide faster restoration of service after the line is sectionalized. Automatic restoration times are typically on the order of seconds. The communications link can also enable the relays to be accessed by the SCADA system for metering and system status data as well as for remote control of the protection and sectionalizing devices.

Because the entire line could be supplied through one breaker with the other breaker open, the phase and ground overcurrent relays at the breakers are set to coordinate with the largest or highest-set protective device on any of the line sections. The line switch relays are set as overcurrent and undervoltage detectors to provide fault location intelligence. Automatic reclosing for the breakers typically consists of an instantaneous open interval, followed by one or more time-delayed open intervals. If a fault occurs on Line 1 in Figure 8-6, Relay 1 at Breaker 1 will detect the fault and trip Breaker 1. Breaker 1 will reclose instantaneously. If the fault is still present, Relay 1 will again trip Breaker 1. Relay 2 will detect an undervoltage condition but no overcurrent and will open LS 2 during the second open interval of Breaker 1. Breaker 1 will then reclose. If the fault is still present, Breaker 1 will trip again and lock out (assuming reclosing for the breaker was set for only two open intervals). At this point, the Line 1 fault is isolated, but Line 2 is also deenergized. Restoration of Line 2 can then be accomplished automatically via the relays or remotely via SCADA commands to the relays. If restoration is done via SCADA, the open status of Breaker 1, LS 2, and LS 5 is transmitted to SCADA over the communications link. The fact that both LS 2 and LS 5 saw an undervoltage condition without fault current is also transmitted to SCADA. This information enables the dispatcher to send a close command to LS 5 to restore service to Line 2. If restoration is accomplished automatically via the relays, then Relay 5 “sees” from Relay 2 via the communications link that Relay 1 operated for a fault but that Relay 2 did not see any fault current and that Line Switch 2 is now open. Therefore, Relay 5 automatically closes Line Switch 5 to restore power to the customers on Line 2.



**Figure 8-6—Communications-enhanced trip and restore scheme on a looped-radial distribution system**

If the line switches in Figure 8-6 are replaced by reclosers with fault current interrupting capability, then the communications link can be used in the tripping scheme as well as the restoration scheme. In this case, Relay 1 and Relay 3 would contain a set of phase and ground overcurrent elements set to coordinate with the largest or highest-set protective device on any line section in order to provide line protection if the communications channel is lost. However, a second set of phase and ground overcurrent elements can also be set in Relay 1 and Relay 3 to coordinate with the largest or highest-set protective device on its individual line section. Similarly, the phase and ground overcurrent elements in Relays 2, 4, and 5 can be set to coordinate with the largest or highest-set protective device on its line section. For example, suppose that Relay 1 is set to coordinate with a 40E fuse as the largest protective device on Line 1 and Relay 2 is set to coordinate with a 100E fuse as the largest protective device on Line 2, and a fault occurs on Line 2. Both Relay 1 and Relay 2 will see the fault, but the overcurrent detector in Relay 2 will send a signal via the communications link to Relay 1 to momentarily suspend timing in order to allow time for Relay 2 to trip its recloser to clear the fault. If Relay 2 is programmed for automatic reclosing, it can close its recloser at least once to test Line 2. The advantage of this scheme is that only Line 2 is taken out of service for the fault, and the customers on Line 1 are subjected to only a voltage sag, instead of a complete outage.

### 8.8.4 Communications-aided trip

On a looped distribution system, fault-interrupting switchgear can be equipped with directional relays having communications capability to provide automatic clearing of any faulted line section within a few cycles to greatly limit the duration of voltage sags and minimize the number of customers subjected to an interruption in service (see “International Drive Distribution Automation and Protection” [B20]). An example of a looped distribution system equipped with directional relays and fault-interrupting switchgear appears in Figure 8-7. Because these are typically underground distribution systems, neither the substation breakers nor the fault-interrupting switchgear is equipped with automatic reclosing. Application of directional elements and logic in the relays with the communications links enables the looped system to be protected using the same communications-assisted protection schemes that are in common use on high voltage transmission lines. For example, a permissive overreaching transfer trip (POTT) scheme could be implemented in relay logic to provide primary protection for each line section in Figure 8-7. If a fault occurs on Line 2, the forward-looking directional element in Relay 3 will “see” the fault and send a permissive trip signal to Relay 4. Similarly, the forward-looking directional element in Relay 4 will “see” the fault and send a permissive trip signal to Relay 3. The combination of a forward-looking directional

element asserted plus a permissive trip signal from the remote relay causes both Relay 3 and Relay 4 to trip their associated switches to clear the fault.

Note that while the forward-looking directional elements in Relays 1 and 6 may also “see” the fault on Line 2, they will not receive a permissive trip signal from their remote terminals and therefore will not trip their respective fault-interrupting switches. Thus, all customers may see a momentary voltage dip, but only the customers associated with Line 2 will experience an outage.

In addition to the directional elements required for the POTT scheme, backup time-delay phase, and ground overcurrent elements in Relays 2 through 7 should be set to coordinate with the protective device settings on the load feeder switches. Similarly, backup time-delay phase and ground overcurrent elements in Relays 1 and 8 should be set to coordinate with the overcurrent settings in Relays 2 and 7, respectively. As in the looped-radial system, the communications link can also provide SCADA system access to the relays for metering and system status data as well as for remote control of the protected equipment.

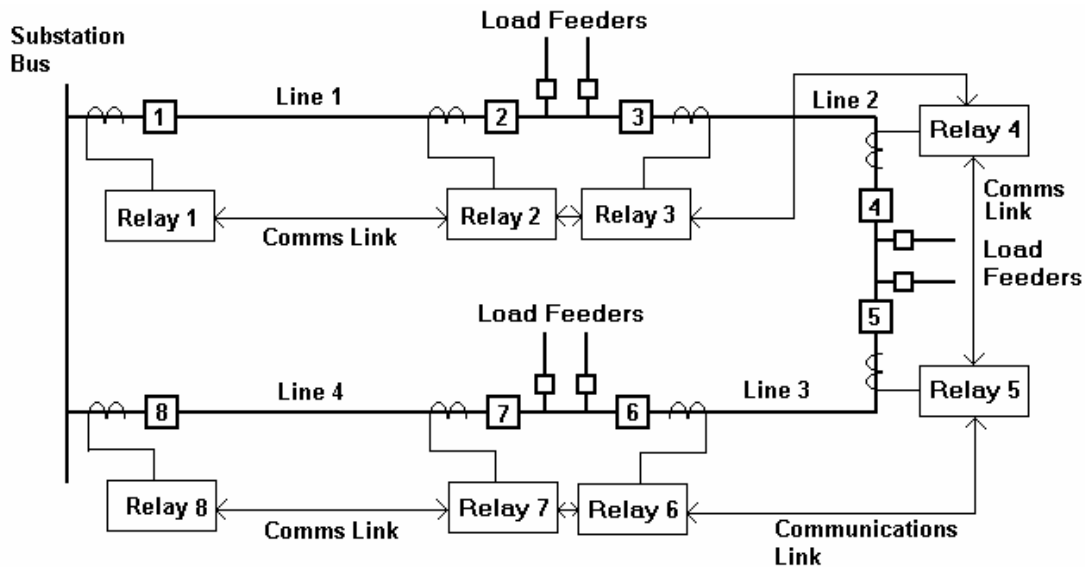

Figure 8-7—Communications-aided trip scheme on a looped distribution system

## 8.9 Multiple source configurations

Radial feeders are the most common types of distribution feeder. However, there are cases where the protection on such lines would not accommodate a line with multiple sources. If the line is a two- or three-terminal line, a line with DRs, or a line networked with other adjacent stations on the low voltage side; then the protection may be inadequate. The distribution engineer should also take into account cases where a line switch may be closed to energize a second line. Through the use of settings groups, various line switching configurations may be accommodated. SCADA or distribution automation systems may be used to automate, the settings group changes.

Cases with two, three, or more main terminals (this could also include lines with emergency ties) may require directional overcurrent relays. The use of impedance type relays may be considered. A dependable polarizing source at the substation is required and this may not be possible at locations that are “weak,” especially for the ground protection.

Lines with DRs or other source stations may also require the use of directional overcurrent relays. The ground overcurrent relay settings may be compromised if the DRs or backfeed station is a zero-sequence current source. Negative-sequence overcurrent relays may also have to be incorporated where the normal zero-sequence current protection may be compromised.

Distribution lines that are mostly cable and have substations that can provide backfeed through a line side delta connected transformer as shown in Figure 8-8 warrant review. The use of a primary side VT with an overvoltage/undervoltage relay may be considered to provide protection for primary side faults on the system.

Lines that have tie switches can be troublesome to set the overcurrent relays. These settings are based on the farthest location that the relay should protect. That could be at the farthest end of the line that is being “picked up” by the good line.

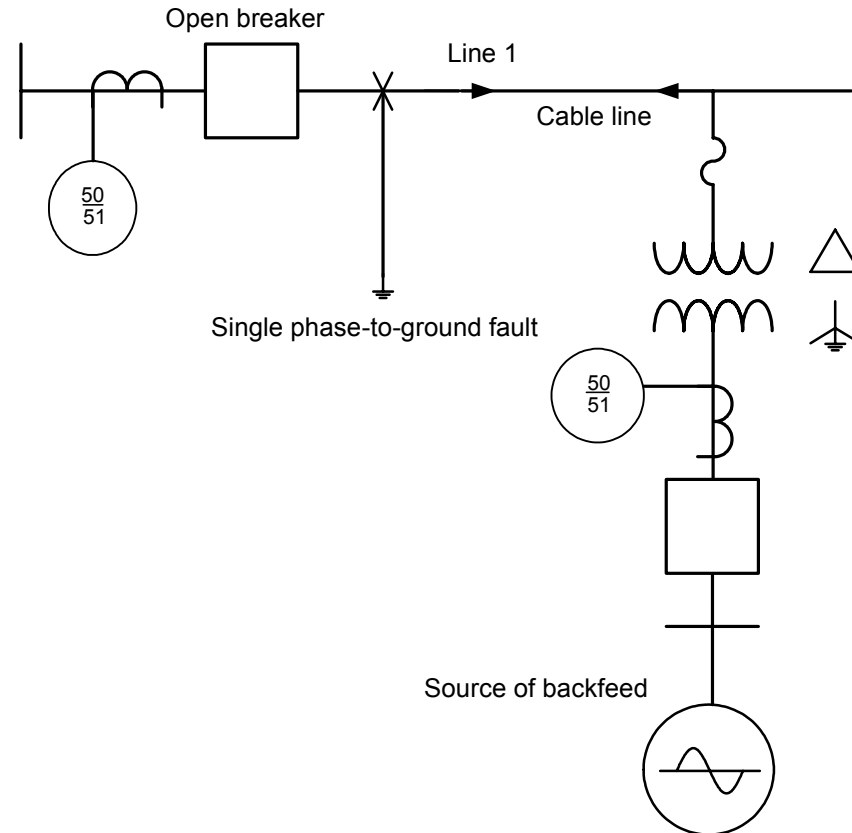

**Figure 8-8—Line with a source of backfeed**

### 8.10 Directional overcurrent relay

Directional overcurrent relays discern the direction of current flow to a fault, thereby permitting overcurrent relay operation for faults in one direction, and blocking relay operation for faults in the other direction. They are most commonly applied on networked circuits, or distribution circuits that have DRs. Directional phase overcurrent relays have the same restrictions as non-directional phase overcurrent relays for load flow in the tripping direction.

Directional overcurrent relays typically consist of a directional element in combination with an overcurrent relay. Ground directional elements are able to detect the direction of a ground fault and are typically combined with a ground overcurrent relay that operates on residual ground current, zero-sequence current, or CT neutral ground current. Phase directional elements are able to detect the direction of three-phase and phase-to-phase faults and are typically combined with a phase overcurrent element that operates on phase current. Negative-sequence directional elements, able to detect the direction of phase-to-phase and ground faults, may also be combined with phase and ground overcurrent elements. Properly selected directional elements block tripping for load flow and faults in the non-tripping direction.

As with non-directional overcurrent relay schemes, instantaneous and definite-time trip units, which may or may not be directionally controlled, can be added to directional time-overcurrent relay schemes to provide high-speed relay operation for close-in faults. Where the source on one side of the relay terminal is much stronger than the source on the other side, non-directional overcurrent elements set to pickup above the maximum current available from the weaker source will be inherently directional because they can only operate for faults driven by the stronger source. Directional overcurrent relays are required where the relay scheme must have different sensitivity or operate time for faults in one direction compared with the other direction.

Input currents to the directional overcurrent relays are provided from CTs located at the line terminal, one for each phase overcurrent unit, and the sum of the three for the residual ground or neutral overcurrent unit. Three-phase devices may have a single-phase overcurrent unit that operates on maximum phase current, or it may have three phase overcurrent units that operate on their respective phase current. Three-phase devices may also sum the currents internally to produce negative-sequence and residual ground (zero-sequence) operating quantities without the need for additional CT connections.

The time-overcurrent and instantaneous units used in directional overcurrent relay schemes are virtually identical in operation and design to those used in non-directional overcurrent relay schemes, with the exception that the operation of one or both units will be controlled or supervised by the directional element.

The directionality of the directional element is accomplished by providing the relay with a measured reference quantity. This input can be a voltage, a current, or both. Phase voltage, or positive-sequence voltage, is required to polarize the phase directional element for three-phase faults. Because close-in three-phase faults cause all three-phase voltages to collapse to zero, the phase directional element polarization voltage must include a memory function to provide proper directionality long enough for the time-overcurrent element to operate. Phase voltage, positive-sequence voltage, or negative-sequence voltage can be used to polarize the phase directional element for phase-to-phase faults. Negative-sequence voltage, zero-sequence voltage, or zero-sequence current from a separate zero-sequence current source, can be used to polarize a ground directional element. A combination of two or all three of these can be used to ensure dependable directional element operation under various system configurations and conditions. Negative-sequence polarized directional units are often applied when zero-sequence mutual coupling effects cause zero-sequence directional units to lose directionality, or cause false operation. Negative-sequence voltage polarization has the added advantage that it can be supplied through wye or delta connected potential transformers. Zero-sequence voltage polarization requires three wye-connected potential transformers.

As with all overcurrent relays, delays for time coordination with other devices are required. Fault coverage and/or operating times may be affected by network changes. The coordinating time delay requirements will often make directional time overcurrent relays unsuitable where extremely high-speed fault clearing is required. However, directional overcurrent relays generally provide adequate operating speed to be used on lower voltage networks, especially as protection for ground faults. Sensitive instantaneous directional overcurrent relay elements can be used in pilot scheme applications to where fast fault clearing is required.

There are two different ways to apply the directional element in directional overcurrent relays. In one method, the directional element supervises the output of the overcurrent element. In this method, the overcurrent element is free to operate for any current in excess of its pickup setting, but tripping occurs only if the directional element also operates. Alternately, the directional element controls the input to the current measuring portion of the overcurrent element, preventing its operation unless the directional element operates. In an electromechanical relay scheme, for example, a directional element contact can be installed in the shading coil circuit of an overcurrent relay to control the overcurrent relay operation. This is often referred to as “torque control” because the directional element controls the operating torque of the overcurrent relay.

Both methods, directional supervision and directional torque control, can be accomplished with electromechanical, solid state, and microprocessor-based relays. One advantage of directionally torque controlling the input to the overcurrent relay is that there is no race between reset of the overcurrent element and operation of the directional element during current reversals, i.e., the directional element must operate before the overcurrent element can operate.

### 8.11 Motors (effects of unbalance)

The effect of three-phase motor unbalance on distribution line protection is primarily dependant upon two things: 1) what percentage the unbalanced motor load is of the total load supplied by the circuit the protective device is on and 2) the type of motor and its connection. Typically, the unbalanced three-phase motor load is a small portion of the total load “seen” by the protective device. Thus, the effect of unbalance operation on protection is minimal and usually can be neglected.

In general, when a three-phase motor is fed by an unbalanced set of phase voltages (either inherently unbalanced or an open-phase condition), the phase currents drawn by the motor will become unbalanced. The most severe operating condition would be that of an open phase. An open phase is usually the result of a blown fuse; however, this can be caused by a bad connector, etc. Figure 8-9 depicts this typical scenario.

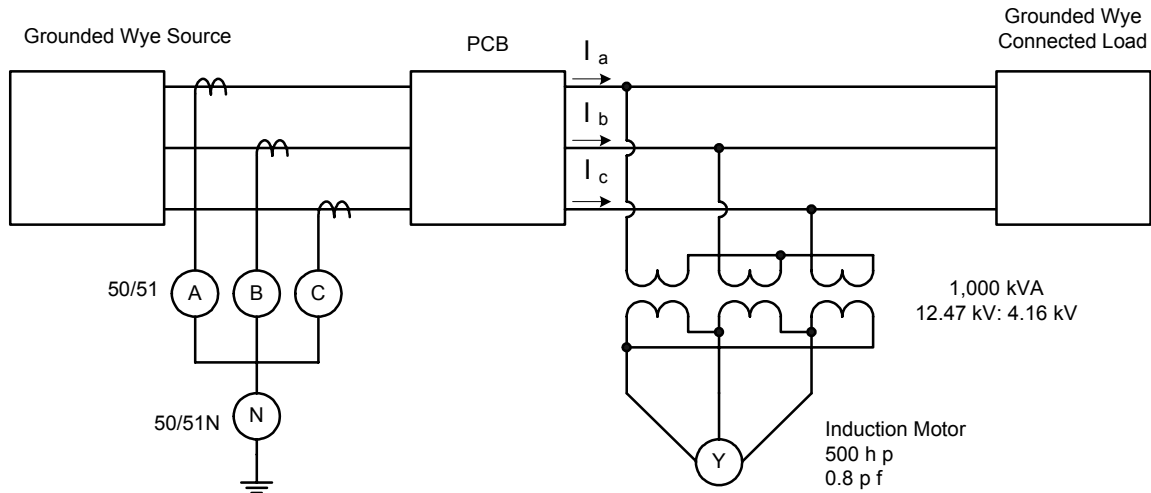

**Figure 8-9—Three-line diagram of a typical open-phase unbalance of a three-phase induction motor**

Although synchronous motors can operate with one phase open, they are likely to pull out of step and be disconnected from the system if they are loaded near their ratings. Therefore, only the induction motor will be addressed here.

When an induction motor is operated with an open phase, the phase currents drawn by the motor will theoretically increase to those shown in Table 8-1 (see also IEEE Std C37.96™-2000 [B45] and “Symmetrical Components for Power System Engineering” [B7]). Note that these values are in per unit of the current values prior to the open-phase condition.

**Table 8-1—Theoretical line currents for open-phase condition**

	Normal condition (p.u.)	Open-phase condition (p.u.)
Phase a	1.0	0.0
Phase b	1.0	1.732
Phase c	1.0	1.732

Although the line currents drawn by the motor in phases b and c will increase to a theoretical maximum of 1.732 p.u., the magnitude of the phase currents,  $I_a$ ,  $I_b$ , and  $I_c$  “seen” by the protective device will not change very much if the connected load is much larger than the three phase induction motor load. Therefore, for this case, i.e., the connected load is much larger than the unbalanced motor load; the effect on the protective relaying is negligible.

The following scenario shows a situation where the unbalance could potentially become a problem. To illustrate the point, assume that the system shown in Figure 8-10 is rated at 12.47 kV line-to-line and the induction motor is operating at full load and has a rating of 500 HP 0.8 pf lag (assume 1 HP = 1 kVA). The connected load is 5 MVA at 0.8 pf lagging and is connected grounded wye. Neglecting losses (line and transformer), the phase currents “seen” by the protective relays in Figure 8-10 can be shown to be equal to the values shown in Table 8-2.

**Table 8-2—Line current “seen” by protective device in Figure 8-10  
for normal and open-phase conditions**

	Normal condition (A)	Open-phase condition (A)
$I_a$	254.6	231.5
$I_b$	254.6	267.0
$I_c$	254.6	197.8
$I_1$	254.6	231.8
$I_2$	0.0	13.4
$3I_0$	0.0	80.1

Once the open-phase condition occurs, approximately 80 A of zero sequence current begins to flow in the ground relays. Ground relaying would need to be evaluated to insure that it was not set sensitive enough to detect this condition.

There are other rare cases where the connected load to motor load ratio is much smaller. In these instances, the currents resulting from the unbalanced operation of a three-phase induction motor should be taken into consideration when setting protective relays. Phase overcurrent relays should be set such that they can carry 1.732 p.u. load current with some margin keeping in mind that this relay should also be set to “see” end zone phase-to-phase faults. If this cannot be accomplished, load encroachment or negative sequence relays can be used. However, if negative sequence relays are used they should be set such that it will trip for end zone phase-to-phase faults, but not pick up for the open-phase condition.

## 8.12 Breaker failure

Traditionally, breaker failure protection has not been applied on distribution feeder circuits. This is due both to the cost of the breaker failure relay, relative to the improved dependability of the feeder circuit, as well as concerns over the secure operation of the breaker failure relay. Instead of specific breaker failure detection, most feeder circuits rely on backup protection, such as bus overcurrent relays, high-side transformer overcurrent relays, or transformer ground overcurrent relays, to clear feeder faults during a breaker failure condition. These backup protection functions typically have pickup set to a high level for secure operation during maximum load conditions, so these functions may not have the sensitivity necessary to operate for some feeder faults during a breaker failure condition.

Breaker failure relays, applied to distribution feeder circuits, can improve dependability by clearing feeder faults during a breaker failure condition. In particular, multi-function numerical feeder protection relays that include breaker failure elements allow the application of breaker failure protection at low cost. Breaker

failure elements can be used to re-trip the feeder breaker, and to trip upstream breakers, such as the bus breaker/transformer low-side breaker (if existing), or the transformer high-side interrupting device.

When considering the application of breaker failure protection to distribution feeder circuits, it is important to consider several factors. To develop a dependable and secure breaker failure scheme, understanding how the relay determines circuit breaker position, when the breaker failure timer starts, how breaker failure interacts with reclosing, and the operating conditions of the circuit breaker is necessary.

Breaker failure relays, or breaker failure elements, use different criteria to determine the position of the circuit breaker. Relays may determine circuit breaker status by the position of breaker contacts, by the level of measured current flow through the breaker, or a combination of both contact status and current flow. The breaker failure element timer typically starts when a trip command is issued, but in some relays, only starts after the trip command minimum duration time expires. Breaker failure relays may interact with reclosing elements in different fashions. When a breaker failure element trips, it may prevent the issuing of a breaker reclose signal, block reclosing, or drive reclosing to lockout. The breaker failure time delay needs to be long enough to allow a circuit breaker to operate, and account for breaker operating conditions, such as temperature, age and type of the circuit breaker, and general operating experience with circuit breakers.

### 8.13 Single-phase tripping

With the increasing interest in power quality and minimizing interruptions, single-phase tripping offers an alternative to three-phase tripping when the loads are single phase. For example, suppose a recloser with the single-phase trip option were protecting a feeder. The feeder experiences an “A” phase-to-ground permanent fault. Rather than tripping all three phases for the fault, the recloser trips only the “A” phase. Customers connected to the other two phases, or 67% of the customers in the area assuming balanced loads, do not experience a service interruption due to the fault nor the loss of service due to the recloser locking out after a predetermined number of operations.

Care should be taken using single phase tripping in conjunction with floating wye or delta connected capacitor banks. With “A” phase protective device open due to a temporary fault, the line-to-neutral connected loads on phase “A” are energized from phases “B” and “C” through the capacitor bank. This can produce overvoltages on the phase-to-neutral connected load on the open phase and cause failure in customer equipment. It is not a good practice to install floating wye or delta capacitor banks beyond the location of the single-phase interrupters in three-phase circuits.

Single-phase tripping can also produce another negative effect if used on a circuit with three-phase motor loads. Single-phasing three-phase motors, as would be done with single-phase tripping, can damage these motors, as the current in the motor increases as shown in 8.10. It is generally accepted that the customer has the responsibility to protect their own three-phase motors against single-phasing, however it may benefit the power supplier to also consider this condition. In circuits with mixed single-phase load and three-phase motor load, the power supplier may weigh the benefits of the increased reliability that can be attained through single-phase tripping against the potential value of helping customers with three-phase motor loads.

When single-phase interrupters are used in three-phase circuits, ferroresonance is possible during ungrounded faults as shown in Figure 8-10. In this circuit, an ungrounded phase-to-phase fault opens phases A and B protective devices. This establishes a circuit where ferroresonance is possible with the grounded-wye capacitor bank and the floating wye-delta connected transformer bank. Whether ferroresonance will occur depends on the amount of load connected to the floating wye-delta bank, and whether load is connected phase-to-neutral on primary phases A and B on the load side of the single phase interrupters. If this load is large enough it shunts out the capacitor bank, preventing ferroresonance.

## 8.14 Resonant grounding in distribution systems

Grounding practices in distribution systems are the subject of extensive research in order to find arrangements that best meet the requirements of modern systems. For technical and legal reasons, the methodology used in treating the neutral has developed differently in different countries.

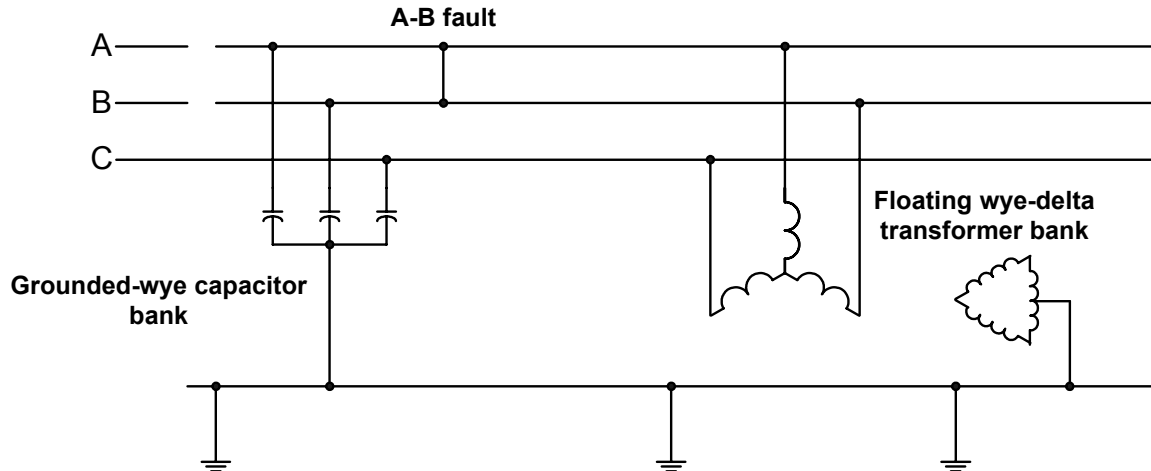

Figure 8-10—Ungrounded system where ferroresonance could occur

If the load is only connected between phase conductors, not between phase and neutral, during normal system operation, the grounding method does not have a relevant impact, except on how the customers' load can be connected. However, the consequences of ground faults on the system depend to a large extent on the grounding method chosen. In systems with low-impedance grounding, faults involving ground cause a considerable fault current, sometimes requiring complex grounding facilities, although at the same time, these large currents allow the faults to be detected and rectified quickly.

However, in the case of grounding systems using a resonant coil, the fault current is reduced to a low value, because the inductive reactance of the coil compensates the capacitive reactance of the system at all times. Using resonant-grounded systems, transient outages are automatically eliminated with no necessity to actuate on the switches or fuses. Therefore, service is not interrupted and the power supply may be maintained during the fault. Presently, resonant grounding is used extensively in the countries of northern and central Europe.

### 8.14.1 General aspects of resonant grounding systems

A resonant grounding system has a variable single-phase reactance, connected between the neutral of a transformer and the earth. The inductive current of the coil cancels the capacitive fault current, so that the current that circulates through the fault point is reduced to a small resistive component. This residual current is originated by the conductances in parallel with the grounding capacities of the system, the losses of the coil itself, and the resistance of the arc.

Some of the most important advantages of using the resonant coil as a grounding method are as follows:

- Compensation reduces the fault current to levels established by electrical safety regulations, for which increases in the grounding voltage can be achieved at a reasonable cost.
- The number of high-speed automatic reclosures caused by grounding faults is reduced between 70% and 90%, thus reducing the number of transitory clearances in a network.
- The need for maintenance of the switches is reduced.

- The voltage increase after extinction of the arc is slow, thus reducing the risk of restarting the arc.
- For a single-line-to-ground fault on the system, it is possible to operate for a space of several hours, even when the fault persists.
- Due to the compensation, when a network operates for a permanent ground fault condition, the power dissipated in the fault is very small.
- The self-extinguishing effect exerted by the compensation reduces the possibility of a single-line-to-ground fault developing into a multi-phase fault.

However, this method of grounding also involves the following drawbacks:

- In protection systems using traditional technology, the reliability and sensitivity of the relays is reduced
- The difficulty of locating faults is increased
- High maintenance
- During a single-line-to-ground fault, the line-to-ground voltages of each unfaulted phase increase by a factor approaching the  $\sqrt{3}$ . Due to economic considerations, this limits implementation of this type of grounding to lower voltage systems, since line-to-line voltage rated insulation would be required.
- The increased voltage experienced raises the probability of simultaneous ground faults developing due to increases in weak points in the system.

The first two drawbacks are being overcome with the development of new fault detection and protection technologies (see “Detection of resistive single-phase earth faults in a compensated power-distribution system” [B57], “Le traitement du point neutre dans les réseaux de moyenne tension” [B26], and “Détection de défauts à la terre très résistants sur les réseaux compensés” [B16]). Due to the last two drawbacks, in order to make it possible to adopt the resonant grounding system, a preliminary analysis will have to be made of effects that the voltage surges in sound phases might have on insulation in the electrical system. To prevent any harmful effects, it will be necessary to ascertain the weak points in the system and also to check that all equipment has been designed to support new voltage demands.

#### 8.14.2 Methods of detecting ground faults in resonant-grounded systems

The high magnitude of the zero-sequence impedance makes the much smaller positive- and negative-sequence network impedances negligible, and can be ignored without much loss of accuracy when evaluating single-line-to-ground faults on resonantly grounded power systems. The zero-sequence used for forward and reverse single-line-to-ground faults in resonant-grounded systems is shown in Figure 8-11 and Figure 8-12. For this analysis, the assumption is that the conductance of the power system is infinite. Stated another way, the insulators are perfect, and the system is perfectly balanced beforehand. This means that the driving voltage of the fault is the pre-fault line-to-neutral voltage.

Examining the zero-sequence network for a forward fault, the zero-sequence current,  $I_0$ , for a perfectly tuned system is  $180^\circ$  out of phase with the zero-sequence voltage,  $V_0$ . However, most systems are generally over- or under-tuned, which simply causes the zero-sequence current to either lead the zero-sequence voltage by more than  $90^\circ$  or lag the zero-sequence voltage by more than  $-90^\circ$ . Calculating the torque/real power in all the above cases provides a negative result.

Examining the zero-sequence networks for a reverse fault shows that the zero-sequence current for a perfectly tuned system is in phase with the zero-sequence voltage. The zero-sequence current for a reverse fault on an over- or under-tuned system causes the zero-sequence current to either lead the zero-sequence voltage by less than  $90^\circ$ , or lag it by less than  $-90^\circ$ . In all cases the torque, or real power, developed is positive.

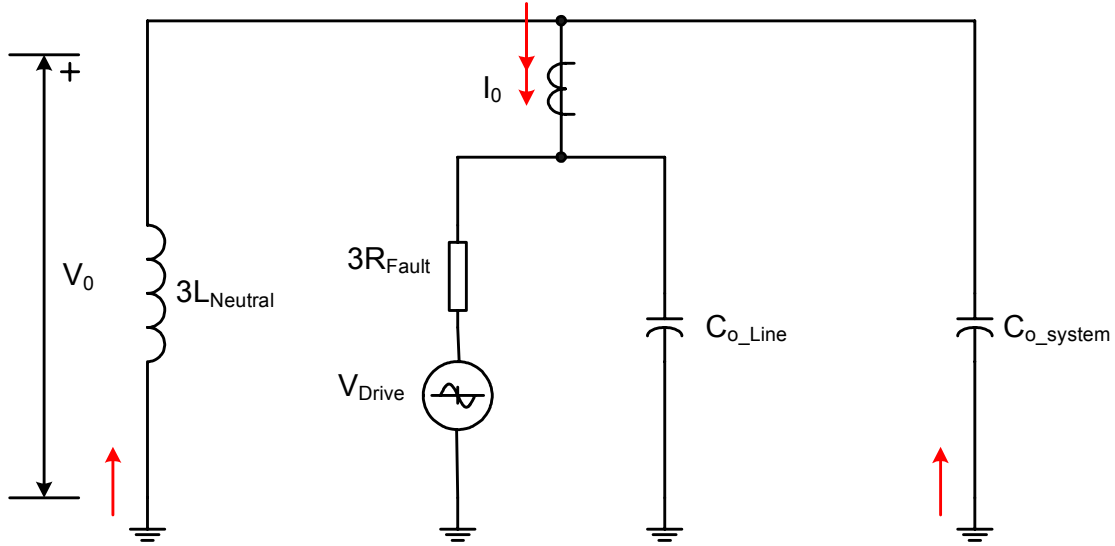

Figure 8-11—Zero-sequence network diagram for a forward fault

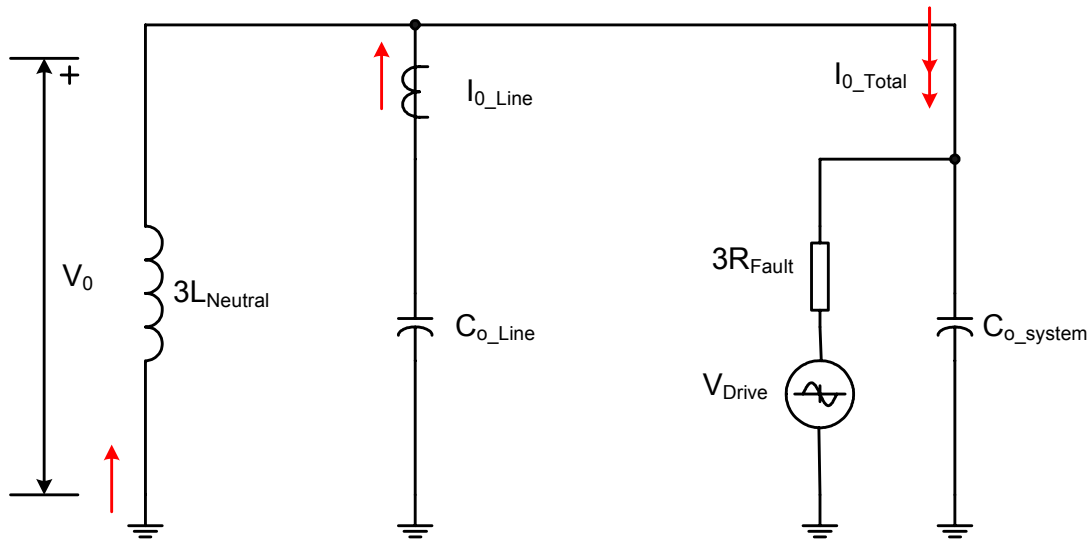
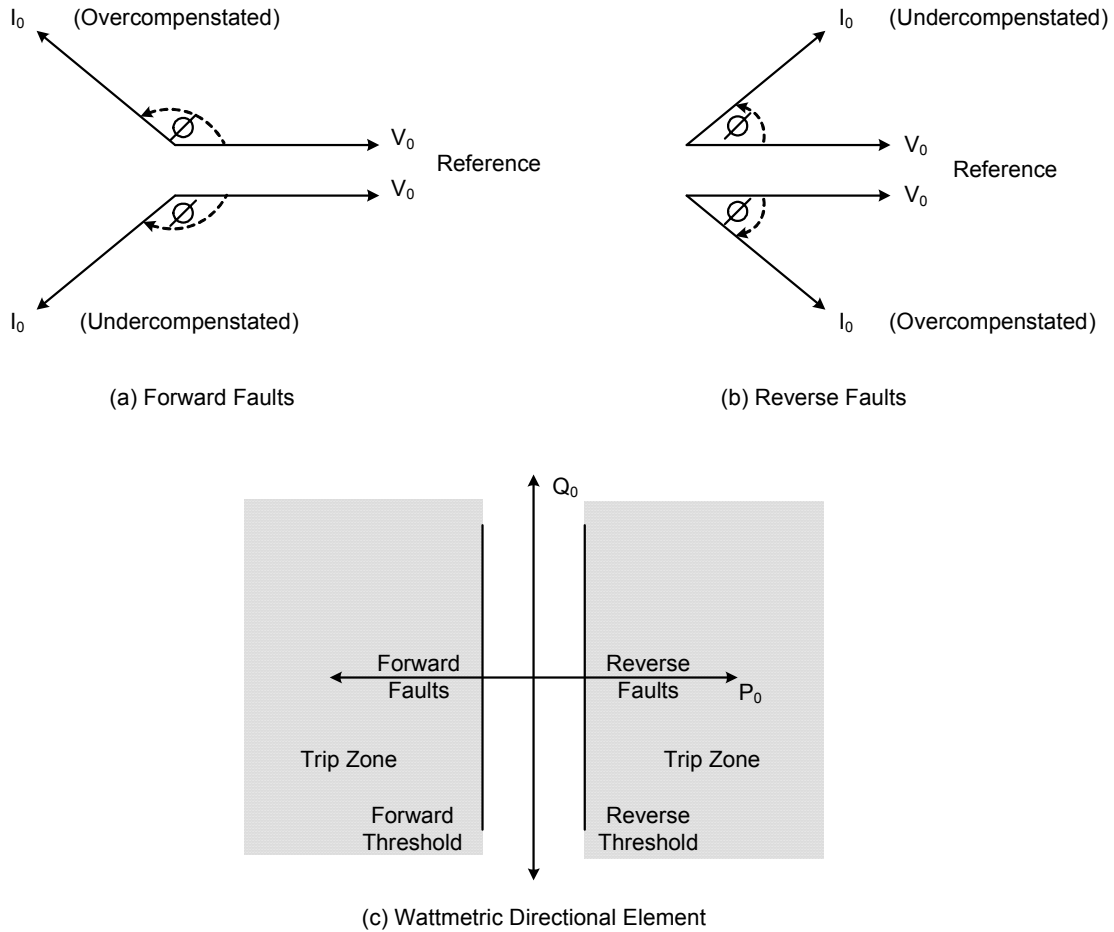

Figure 8-12—Zero-sequence network diagram for a reverse fault

Therefore, using this information, a negative power is developed for a forward fault, and a positive power is developed for a reverse fault. A wattmetric element (an element that calculates real power) can be used with the following logic:

- If the power developed is less than a set negative threshold, the fault is forward.
- If the power developed is greater than a set positive threshold, the fault is reverse.

Figure 8-13 shows the phasor diagram for the wattmetric element.



**Figure 8-13—Phasor diagram for the wattmetric element**

The sensitivity of the wattmetric element is inhibited by the standing unbalance of the power system. However, where utilities require fault detection for faults that may generate voltages or currents that are less than the standing unbalance of the power system, the incremental conductance method is used. This method calculates the incremental change in the conductance of the power system. To calculate the incremental conductance, the incremental change in current is divided by the incremental change in voltage, where the incremental change in current is the difference between the prefault current and the fault current, and the incremental change in voltage is the difference between the prefault voltage and the fault voltage. If the calculated change in conductance is positive, the fault is forward. If the calculated change in conductance is negative, the fault is reverse. See “Methods for detecting ground faults in medium voltage distribution power systems” [B21].

### 8.15 Selective ground fault protection of an ungrounded system

Ground faults on delta connected systems and on systems with isolated neutral can selectively be detected by highly sensitive residual overcurrent relays directionalized by residual voltage. The existing applications involve detection of a ground fault condition by a residual voltage element, but the individual feeder with the fault can only be determined by a trial-and-error method based on sequentially opening of each feeder one by one until the residual voltage disappears.

However, during ground faults, ground becomes identified with the faulted phase voltages as shown in Figure 8-14. Therefore, capacitive charging currents flow between the healthy phases and ground. These currents appear as a residual current at the relay location, in the opposite direction of the current flowing to the fault. Since these currents are based on line capacitance to ground, the current magnitude may be in the range of milliamps of secondary current, significantly less than load current.

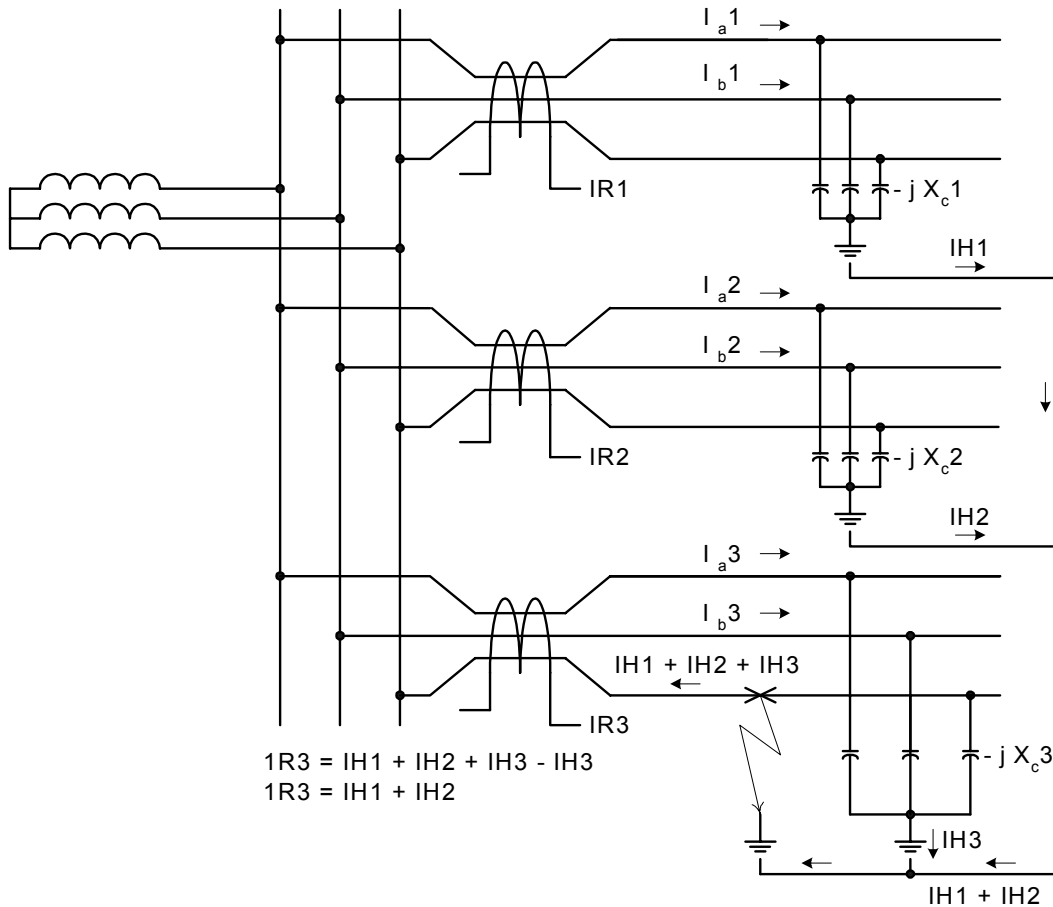

Figure 8-14—Current distribution in an ungrounded system with C-phase fault

### 8.15.1 Ground fault detection techniques

There are two methods commonly used to selectively detect ground faults on ungrounded systems. Varmetric relays are applied on isolated neutral systems, where wattmetric relays are applied on compensated neutral systems. Both methods use a component of the residual current that is perpendicular to the direction of the system displacement voltage. Therefore, these methods require the use of three VTs to provide displacement voltage to the relay.

#### 8.15.1.1 Varmetric relays

Varmetric relays respond to the quadrature (imaginary) component of the zero-sequence current compared to the displacement voltage. In an isolated neutral system, capacitive current flows from the healthy lines via the relay location to the fault. Therefore, the residual current contains a strong capacitive component that can be used to determine fault direction.

### 8.15.1.2 Wattmetric relays

Wattmetric relays use the in-phase (real) component of zero-sequence current as compared to the displacement voltage. In a compensated neutral system, the arc suppression coil superimposes an inductive current on the capacitive ground fault current, when a ground fault occurs. The resulting fault current at the relay location may be inductive or capacitive, depending on the size of the arc suppression coil versus the capacitance. Therefore, only the resistive residual current from the arc suppression coil provides a consistent value for determining fault direction.

### 8.15.2 Setting guidelines

Both varmetric and wattmetric relays typically have a pickup setting based on the minimum available residual current. In addition, some relays also use the magnitude of displacement voltage as an additional pickup criterion. For an isolated neutral system, the current pickup criterion is based on the total capacitive ground current of the connected system flowing through the relay. A pickup setting of about half the capacitive current value of ground current is typical.

A compensated neutral system uses a highly accurate and very sensitive pickup setting for the residual current. The magnitude and angle of the in-phase residual component varies with the position of the arc suppression coil relatively to the system configuration. A typical pickup setting is a value at half the amount of current resulting in losses from the arc suppression coil. Due to the low sensitivity required, highly accurate cable core balance CTs are typically required. Some wattmetric relays have pickup sensitivity to 1 mA of secondary current. In addition, some wattmetric relays have the ability to compensate for CT measurement error, when known.

During a ground fault, the entire displacement voltage typically appears at the relay. Therefore, when pickup settings for voltage displacement are required, the settings can be quite large, in the range of 30 V to 60 V secondary.

## Annex A

(informative)

### Bibliography

- [B1] ABB, *Protective Relaying Theory and Applications*. New York: Marcel Dekker, pp. 145–147, 1994.
- [B2] ABB Power T&D Company, Inc., *Electrical Transmission and Distribution Reference Book*, Fifth Edition, Raleigh, NC: Electric Systems Technology Institute, 1997.
- [B3] ANSI C57.12.10-1997, American National Standard for Transformers—230 kV and Below 833/958 through 8333/10 417 kVA, Single-Phase, and 750/862 through 60 000/80 000/100 000 kVA, Three-Phase Without Load Tap Changing; and 3750/4687 through 60 000/80 000/100 000 kVA with Load Tap Changing—Safety Requirement.<sup>5</sup>
- [B4] Automatic Reclosing on Distribution Systems—Distribution Relay Application School, Basler Electric, June 2002
- [B5] Biscaglia V., et al. “Messa a terra del neutro delle reti MT mediante impedenza di accordo. Analisis tecniche,” *L’Energia Elettrica*, vol. 74, no. 1, pp. 11–20, Jan./Feb. 1997.
- [B6] Blackburn, J. L., *Protective Relaying Principles and Applications*. New York: Marcel Dekker, 1988.
- [B7] Blackburn, J. L., *Symmetrical Components for Power System Engineering*. New York: Marcel Dekker, 1993.
- [B8] Brown, H. H., and Gross, E. T. B., “Practical experience with resonant grounding in a large 34,5 kV system,” *AIEE Transactions*, vol. 69, pt. 2, pp. 1401–1408, 1950.
- [B9] Brown, P. G., Johnson, I. B., and Stevenson, J. R. “Generator neutral grounding: Some aspects of application for distribution transformer with secondary resistor and resonant types,” *IEEE Transactions on Power Apparatus and Systems*, vol. PAS-97, pp. 683–694, May/June 1978.
- [B10] Chaari, O., et al., “Wavelets: a new tool for the resonant grounded power distribution systems relaying,” *IEEE Transactions on Power Delivery*, vol. PWRD-11, no. 3, pp. 1301–1308, July 1996.
- [B11] Concordia, C., “Representation of loads,” *IEEE PES Winter Power Meeting*, New York, Monograph 75-CH 0970-4-PWR, pp. 41–45, 1975.
- [B12] Cooper Power Systems, *Electrical Distribution-System Protection*, Bulletin 90020, Third Edition, Highland, IL, 1990.
- [B13] Dalke, G., “Myths of protecting the distributed resource to electric power system interconnection,” *28th Western Protective Relaying Conference*, Spokane, WA, Basler Electric Company.
- [B14] Das, R., Sachdev, M. S., and Sidhu, T. S., “A fault locator for radial subtransmission and distribution lines,” *IEEE Power Engineering Society Summer Meeting*, Seattle, WA, Paper No. 0-7803-6423-6/00, July 16–20, 2000.
- [B15] Dolezilek, D., Roberts, J., and Zimmerman, K., “Using SEL-351s and SEL-351Rs to Provide Automated Load Restoration for Distribution Feeders,” Schweitzer Engineering Laboratories, Application Guide AG98-06, July 1998.
- [B16] Druml, G., “Détection de défauts à la terre très résistants sur les réseaux compensés,” *REE*, ISSN 1265-6534, no. 2, pp. 68–75, Feb. 1996.

---

<sup>5</sup> ANSI publications are available from the Sales Department, American National Standards Institute, 25 West 43rd Street, 4th Floor, New York, NY 10036, USA (<http://www.ansi.org/>).

- [B17] El-Hawary, M. E., “Incorporation of load modeling in load flow studies,” *Transactions of the Engineering and Operating Division, Canadian Electrical Association*, vol. 22, pt. 4, Paper No. 83-SP-160, pp. 1–14, 1983.
- [B18] Elneweih, A. F., Schweitzer, III, E. O., and Feltis, M. W., “Negative-sequence overcurrent element application and coordination in distribution protection,” *IEEE Transactions on Power Delivery*, vol. PWRD-8, no. 3, pp. 915–924, July 1993.
- [B19] EPRI EL-3085, Project 1209-1, *Distribution Fault Current Analysis*, Final Report, Burke, J. J., Douglass, D. A., and Lawrence, D. J.
- [B20] Fairman, J. R., Gregory, J. W., Niemira, J. K., and Zimmerman, K., “International drive distribution automation and protection,” *Proceedings of the 26th Annual Western Protective Relay Conference*, Spokane, WA, Oct. 2000.
- [B21] Fischer, N., and Hou, D., “Methods for detecting ground faults in medium voltage distribution power systems,” White Paper, Schweitzer Engineering Laboratories, Inc., Oct. 10, 2006.
- [B22] Griffel, D., Harmand, Y., and Bergeal, J., “Nouvelles techniques de mise à la terre des neutres sur les réseaux MT,” *RGE*, no. 11/94, pp. 35–44, Dec. 1994.
- [B23] Griffel, D., et al., “A new deal for safety and quality on MV networks,” *IEEE Transactions on Power Delivery*, vol. PWRD-12, no. 4, pp. 1428–1433, Oct. 1997.
- [B24] Gross, E. T. B., and Atherton, E. W., “Application of resonant grounding in power systems in the United States,” *AIEE Transactions*, vol. 70, pt. 1, pp. 389–397, 1951.
- [B25] Gulachenski, E. M., and Courville, E. W. “New England’s 30 years of experience with resonant neutral grounding of unit-connected generators,” *IEEE Transactions on Power Apparatus and Systems*, pp. 2572–2578, Sept. 1984.
- [B26] Handschin, E., and König, D., “Le traitement du point neutre dans les réseaux de moyenne tension,” *REE*, ISSN 1265-6534, no. 2, pp. 20–30, Feb. 1996.
- [B27] Heydt, G. T., *Electric Power Quality*, Second Edition. Chelsea, MI: Stars In A Circle Publications, 1991, p. 184.
- [B28] IEC 60076-5:2006, Power Transformers—Part 5: Ability to Withstand Short Circuit (Ed. 3.0).
- [B29] IEEE 100™, *The Authoritative Dictionary of IEEE Standards Terms*, Seventh Edition. New York: Institute of Electrical and Electronics Engineers, Inc.<sup>6, 7</sup>
- [B30] IEEE Power System Engineering Committee, “System load dynamics-simulation effects and determination of load constants,” *IEEE Transactions on Power Apparatus and Systems*, vol. PAS-92, pp. 600–609, Mar. 1973.
- [B31] IEEE PSRC Report, “Distribution Line Protection Practices Industry Survey Results,” Dec. 2002.
- [B32] IEEE PSRC Report, “High-Impedance Fault Detection Technology,” Mar. 1996.
- [B33] IEEE PSRC Report, “Impact of Distributed Resources on Distribution Relay Protection,” Aug. 2004.
- [B34] IEEE PSRC Report, “Transmission Line Protective Systems Loadability,” Mar. 2001.
- [B35] IEEE Std 141™-1993 (Reaff 1999), IEEE Recommended Practice for Electric Power Distribution for Industrial Plants (*IEEE Red Book™*).
- [B36] IEEE Std 241™-1990 (Reaff 1997), IEEE Recommended Practice for Electric Power Systems in Commercial Buildings (*IEEE Gray Book™*).
- [B37] IEEE Std 242™-2001, IEEE Recommended Practice for Protection and Coordination of Industrial and Commercial Power Systems (*IEEE Buff Book™*).

<sup>6</sup> IEEE publications are available from the Institute of Electrical and Electronics Engineers, 445 Hoes Lane, Piscataway, NJ 08854, USA (<http://standards.ieee.org/>).

<sup>7</sup> The IEEE standards or products referred to in this clause are trademarks of the Institute of Electrical and Electronics Engineers, Inc.

- [B38] IEEE Std 519™-1993, IEEE Recommended Practices and Requirements for Harmonic Control in Electrical Power Systems.
- [B39] IEEE Std 1100™-1999, IEEE Recommended Practice for Powering and Grounding Electronic Equipment (*IEEE Emerald Book™*).
- [B40] IEEE Std 1547™-2003, IEEE Standard for Interconnecting Distributed Resources with Electric Power Systems.
- [B41] IEEE P1547.4™, Draft Guide for Design, Operation, and Integration of Distributed Resource Island Systems with Electric Power Systems.<sup>8</sup>
- [B42] IEEE Std C37.2™-1996, IEEE Standard Electrical Power System Device Function Numbers and Contact Designations.
- [B43] IEEE Std C37.90™-1989 (Reaff 1994), IEEE Standard for Relays and Relay Systems Associated with Electric Power Apparatus.
- [B44] IEEE Std C37.91™-2000, IEEE Guide for Protective Relay Applications to Power Transformers.
- [B45] IEEE Std C37.96™-2000, IEEE Guide for AC Motor Protection.
- [B46] IEEE Std C37.104™-2002, IEEE Guide for Automatic Reclosing of Line Circuit Breakers for AC Distribution and Transmission Lines.
- [B47] IEEE Std C37.110™-1996, IEEE Guide for the Application of Current Transformers Used for Protective Relaying Purposes.
- [B48] IEEE Std C37.113™-1999 (Reaff 2004), IEEE Guide for Protective Relay Applications to Transmission Lines.
- [B49] IEEE Std C37.117™-2007, IEEE Guide for the Application of Protective Relays Used for Abnormal Frequency Load Shedding and Restoration.
- [B50] IEEE Std C57.109™-1993, IEEE Guide for Liquid-Immersed Transformer Through-Fault-Current Duration.
- [B51] Khunkhun, K. J. S., et al., “Resonant grounding (Ground fault neutralizer) of a unit connected generator,” *IEEE Transactions on Power Apparatus and Systems*, vol. PAS-96, no. 2, pp. 550–559, Mar./Apr. 1977.
- [B52] Kojovic, L. A., “Roundup: System grounding,” *T&D Electrical World*, vol. 215, no. 1, pp. 28–30, Jan./Feb. 2001.
- [B53] Krein, P. T., *Elements of Power Electronics*. New York, NY, and Oxford, U.K.: Oxford University Press, 1998.
- [B54] Kreyszig, E., *Advanced Engineer Mathematics*, Seventh Edition. New York: John Wiley and Sons, 1993, pp. 577–579.
- [B55] Lakervi, E., and Holmes, E. J., *Electricity Distribution Network Design*. London, U.K.: Peter Peregrinus Ltd., 1989, IEE, ISBN 0 86341 1517.
- [B56] Lawhead, L. P., “Relay Input Sources,” Fifteenth Basler Electric Relay Application School, St. Louis, MO, pp.3–26, June 2004.
- [B57] Leitloff, V., Feuille, R., and Griffel, D., “Detection of resistive single-phase earth faults in a compensated power-distribution system,” *European Transactions on Electrical Power*, vol. 7, no. 1, pp. 65–73, Jan./Feb. 1997.
- [B58] Leitloff, V., Pierrat, L., and Feuillet, R., “Study of the neutral-to-ground voltage in a compensated power system,” *European Transaction on Electrical Power Engineering*, vol. 4, no. 2, pp. 145–153, Mar./Apr. 1994.

---

<sup>8</sup> This IEEE standards project was not approved by the IEEE-SA Standards Board at the time this publication went to press. For information about obtaining a draft, contact the IEEE.

- [B59] Marican, A. M. A., and Griffiths, H., "The effect of different methods of neutral earthing on the performance of power systems under arcing fault conditions," *32nd Universities Power Engineering Conference (UPEC '97)*, UMIST, Manchester, U.K., pp. 343–346, 1997.
- [B60] Prabhakara, F. S., Smith, R., and Stratford, R., *Industrial and Commercial Power Systems Handbook*. New York: McGraw Hill, 1996.
- [B61] REA Bulletin 61-2, "Guide For Making A Sectionalizing Study on Rural Electric Systems," Rural Electrification Administration/U.S. Dept. of Agriculture, Mar. 1978.
- [B62] Roberts, J., and Zimmerman, K., "Trip and restore distribution circuits at transmission speeds," *Proceedings of the 25th Annual Western Protective Relay Conference*, Spokane, WA, Oct. 2001.
- [B63] Shackshaft, G., and Ashmole, P. H., "The influence of load characteristics on power system performance—A C.E.G.B. viewpoint", *CIGRE 1978 Session*, Paper 31-02, Paris, France, Aug. 30–Sept. 7, 1978.
- [B64] Shackshaft, G., Symons, O. C., and Hadwick, J. G., "General-purpose model of power-system loads," *IEEE Proceedings*, vol. 124, no. 8, pp. 715–723, Aug. 1977.
- [B65] Srinivasan, K., and St-Jacques, A., "A new fault location algorithm for radial transmission line with loads," *IEEE Transactions on Power Delivery*, vol. 4, no. 3, pp. 1676–1682, July 1989.
- [B66] Srinivasan, K., Nguyen, C. T., Robichaud, Y., St. Jacques, A., and Rogers, G. J., "Load response coefficients monitoring system: Theory and field experience", *IEEE Transactions on Power Apparatus and Systems*, vol. PAS-100, no. 8, pp. 3818–3827, Aug. 1981.
- [B67] Tomlinson, H. R., and Hunt, F. B., "Operation of a ground-fault neutralizer on a regulated distribution system," *AIEE Transactions*, pp. 1321–1326, 1949.
- [B68] Willheim, R., and Waters, M., *Neutral Grounding in High Voltage Transmission*, ISBN 55-12000, New York: Elsevier Publishing Company, 1956, pp.266–520.
- [B69] Xiangjun, Z., Yongyuan, Y., Youqing, Z., and Qiwen, Y., "On-line distinguishing between resonance and one-phase grounding in distribution network," *Automation-of-Electric-Power-Systems*, vol.22, no. 8, pp. 41–43, Aug. 1998.
- [B70] Y. Qiwen, X. Xiangjun, L. Senran, and L. Weiguo, "The analysis of over-voltage in Petersen coil grounded system," *Journal of Changsha University of Electric Power*, vol. 13, no. 3, pp. 267–271, 1998.
- [B71] Zutobradic, S., and Damianic, M., "Future concept of neutral point grounding in 10(20) kV networks," *Energija*, vol. 48, no. 1, pp. 41–77, 1999.

## Annex B

(informative)

### Glossary

**coordination of protection:** The process of choosing settings or time delay characteristics of protective devices such that operation of the devices will occur in a specified order to minimize customer service interruption and power system isolation due to a power system disturbance.

**fault impedance:** An impedance between the faulted power system phase conductor(s) or between phase conductors and ground.

**impedance relay:** A distance relay in which the threshold value of operation depends only on the magnitude of the ratio of voltage to current applied to the relay, and is substantially independent of the phase angle between the applied voltage and current.

**inverse-time relay:** A relay in which the input quantity and operating time are inversely related throughout at least a substantial portion of the performance range.

**recloser:** A protective device that combines the sensing, relaying, fault-interrupting, and reclosing functions in one integrated unit.

**recloser relay:** A control device that initiates the reclosing of a circuit after it has been opened by a protective relay (or device).

**source impedance (radial system):** The Thevenin equivalent impedance of an electrical system for maximum system short-circuit conditions at the point of interest.